



Technical Manual

IMPORTED

Technical Manual

Section	Page
Material	3
Panel Components	5-6
Colour Range	7
Measuring & Specifications	8-13
Frame Options	14
Louvre Clearance	15
T, Bay & Corner Post Locations	16-18
Layout Configuration (Hinged)	19-21
Track Systems	22-24
Shapes	25
Mount Types	26
Betta Poly & Betta Hybrid	27-23
Betta Basswood Components	31-33
Betta Paulownia Components	33-34
Clearances & Track Systems	35-49
Mid rails/Split tilt	50-52
Stiles	53
Fixed louvre	54
Hardware	55-56

Good



Better



Betta Poly is an extruded material tested for your health containing no harmful phthalates and VOC levels well below Australian standards. Betta Poly is ideal for wet areas such as bathrooms, laundry, kitchens or where water is likely to come into contact with the material, including windows left open. An aluminium insert is used in the stiles, rail and louvres to increase strength and reduce weight. Betta Poly shutters are termite and fire resistant. Panels up to 880mm but if you are looking for wider panels, we have a great option in Betta Hybrid.

Betta Hybrid We combine the water-resistant properties of Betta Poly frames, rails and stiles and then timber louvres to give a light strong hybrid shutter. The timber used is Paulownia, which is a fast-growing timber species due to the propagation of existing root stock. Straight grained, light with a strong grain pattern, high strength to weight ratio and good dimensional stability. Paulownia has a natural resistance to insect damage and is the the best thermal insulating wood. Betta Hybrid panels can span 920mm.

Best



Betta Paulownia

Best



Betta Basswood

Betta Paulownia Paulownia is a fast-growing and highly sustainable hardwood species. It is lightweight, yet durable, and has become popular for its strength, beautiful grain, and resistance to decay. Paulownia has great water-resistant qualities and a high strength to weight ratio.

Betta Basswood is made from 100% Basswood, which is a furniture grade hardwood. It is one of the most widely used materials for shutters in the global market, due to its resistance to warping, easy workability, durability, and its ability to be finished in a variety of colours and stains. Customise with shapes, tracking systems and custom colours. Woodland panels span up to 1000mm

Panel Components

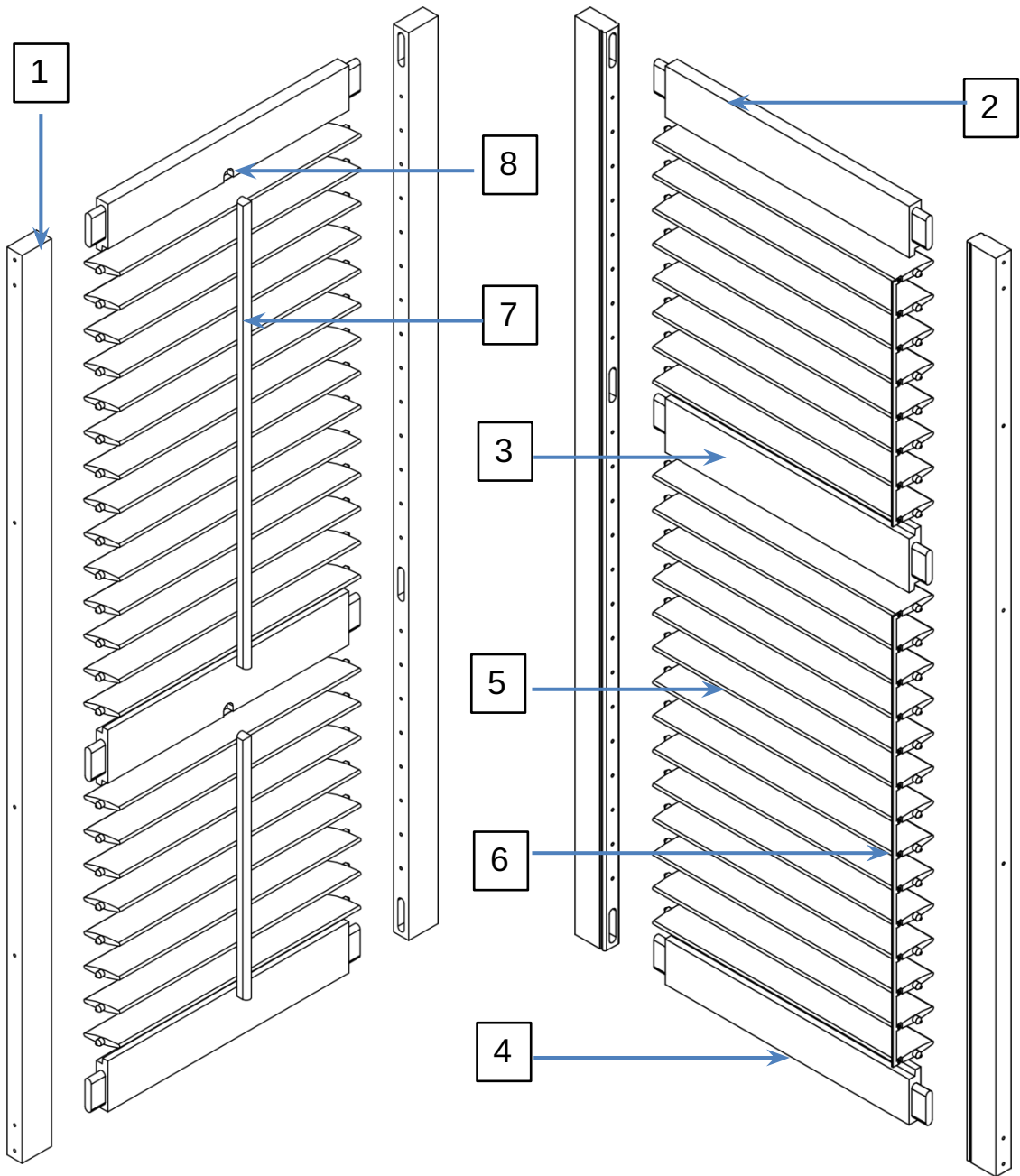

1 Stile

2 Top rail

3 Mid rail

4 Bottom rail

5 Louver

6 Clearview rod

7 Center tilt rod

8 Mouse hole

Invisible Tilt

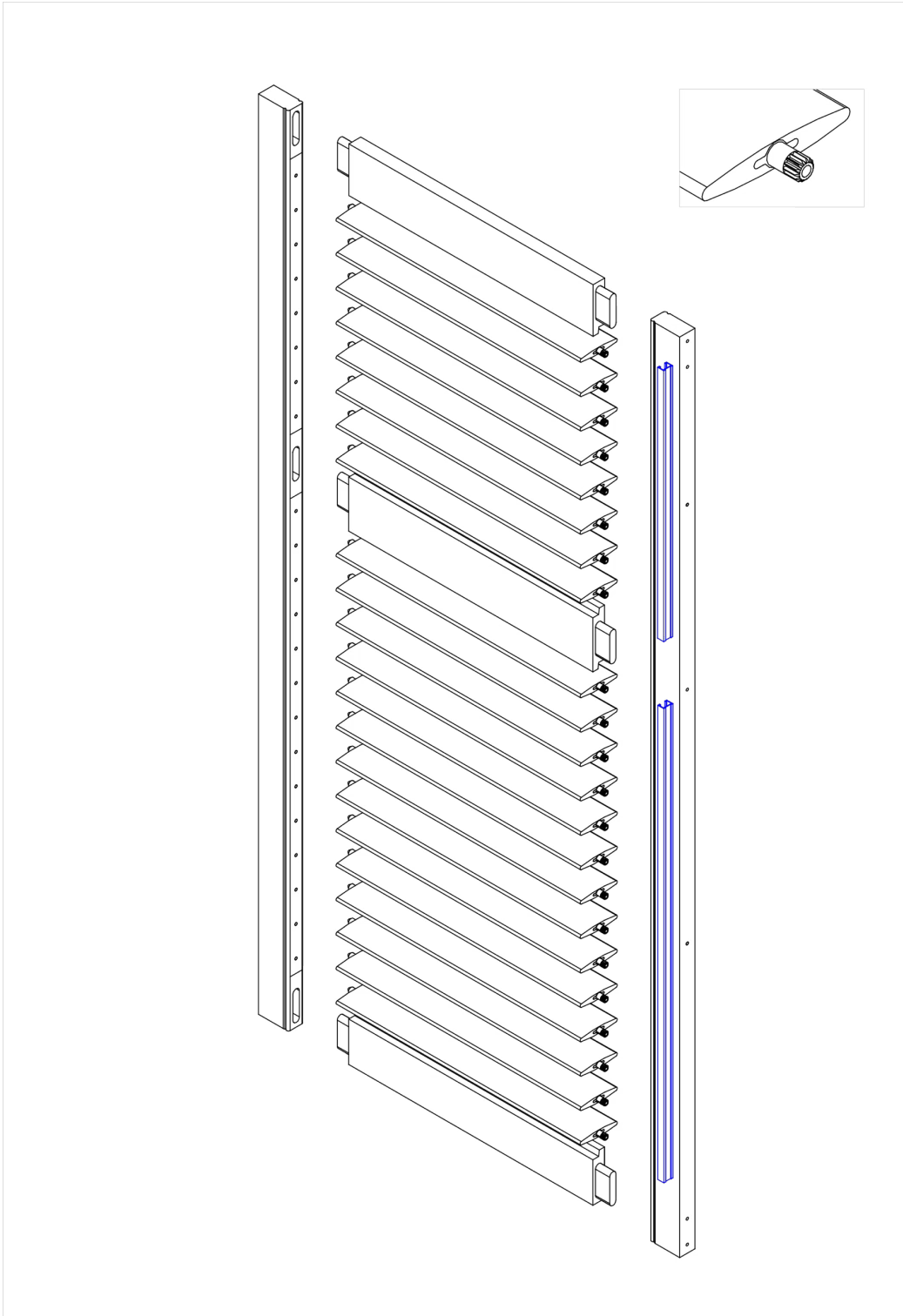

Colour Range

	Betta Poly	Betta Hybrid	Betta Basswood Betta Paulownia	Betta Poly Aussie Made
Polyurethane Paint	JM01 Pure White	JM01 Pure White	JM01 Pure White	
	JM02 Love Note	JM02 Love Note	JM02 Love Note	
	JM03 Super White	JM03 Super White	JM03 Super White	
	JM04 China White	JM04 China White	JM04 China White	
	JM05 Antique White	JM05 Antique White	JM05 Antique White	
Water Based Paint	JM201 Pure White			JM201 Pure White
	JM202 Snow White			
	JM203 Swan			
	JM204 Bright White			
Stains			JM06 Golden Oak	
			JM07 Natural	
			JM08 Cordovan	
			JM09 Walnut	
			JM10 Black	
			JM10 Black	

JM01-JM05: Standard paint (PU)
JM201-JM204: Water based paint
JM06-JM10: Stain



Measuring Guide

Specifications

Material	Betta Poly	Betta Hybrid	Betta Basswood / Betta Paulownia	Betta Poly Australian Made
	Synthetic	Hybrid	Timber	Synthetic
Louvre size	64/89/114mm	64/89/114mm	64/89/114mm	89mm
Max single panel width	880mm	920mm	Paulownia 950mm Basswood 1000mm	880mm
	(64mm=750mm)			
Min. panel width	250mm	200mm	200mm	200mm
Max multi panel width	500mm	550mm	550mm	500mm
Max panel height	2700mm	3000mm	3000mm	2700mm
Min. panel height	300mm	250mm	250mm	300mm
Midrail required at	1800mm	1800mm	1800mm	1800mm
Max. 2nd divider rail		2700mm	2700mm	
Solid Panel	Yes	Yes	Yes	No
Special Shape	No	Yes	Yes	No
T Post	Yes	Yes	Yes	Yes
Bay/Corner Post	Yes	Yes	Yes	Infil
Rebate Stile	Yes	Yes	Yes	Yes
Frame and Post build out	Yes	Yes	Yes	No
Traditional front or offset tilt rod	Yes	Yes	Yes	No
INVISIBLE TILT	Yes	Yes	Yes	No
Clearview	Yes	Yes	Yes	Yes
Track Systems	Yes	Yes	Yes	Yes

* Aust Made we can make the panel size up to 900mm outside of warranty

Standard opening measurement:

Method: Measure top, middle and bottom of the opening width, while measure left, middle and right of the opening height.

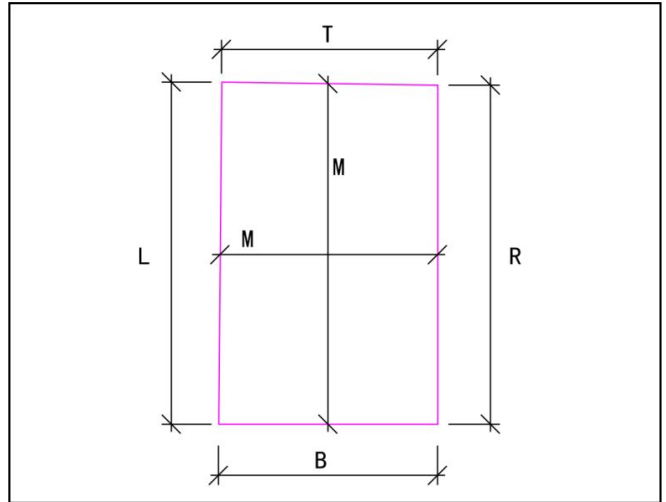
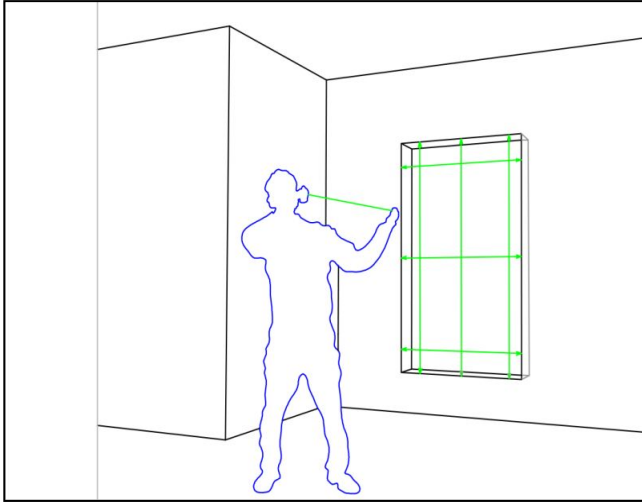

A. Inside Mount

Width=Take the smallest data among the three as width

Height=Take the smallest data among the three as height

Example(A):

top width=703 middle width=705

bottom width=707

left height=1107 middle height=1104

right height=1102

Result:

Width=703

Height=1102

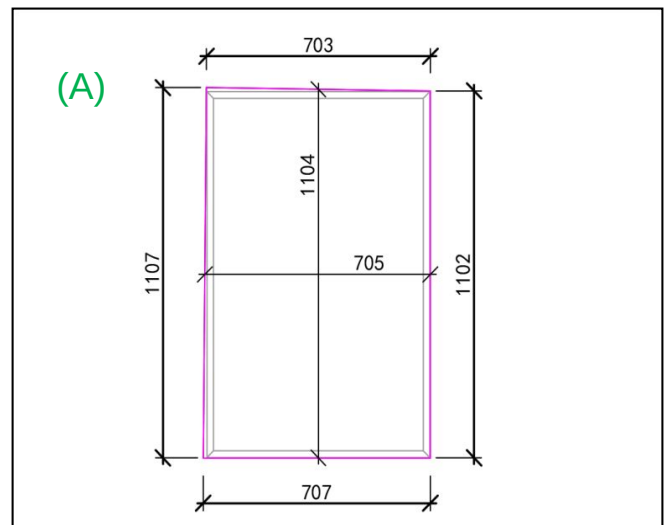

B. Outside Mount

Width:=Take the biggest data among the three as width

Height: Take the biggest data among the three as height

Example(B):

top width=703 middle width=705

bottom width=707

left height=1107 middle height=1104

right height=1102

Result:

Width=707

Height=1107

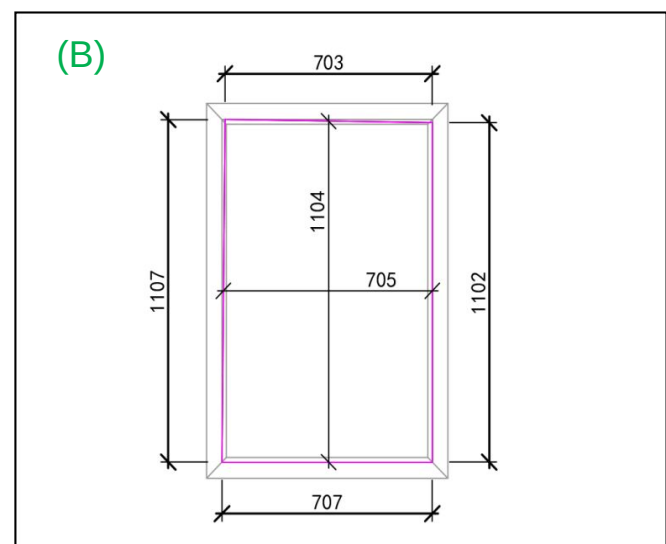

Special shaped opening measurement

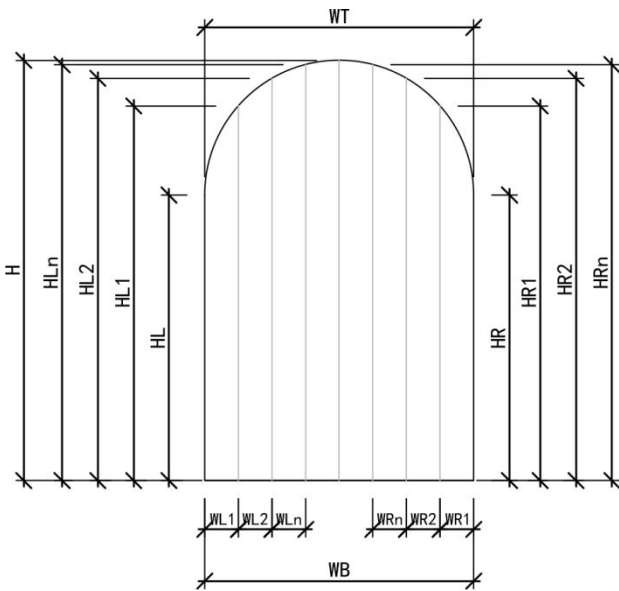

Arch:

Measurement points: See picture(left)

Measurement: Take WB/WT/H/HL/HR
WL1 match HL1, WL2 match HL2, WLn
match HLn

WR1 match HR1, WR2 match HR2, WRn
match HRn

(Measurement points should be added
supposed the opening is bigger or more
special look)

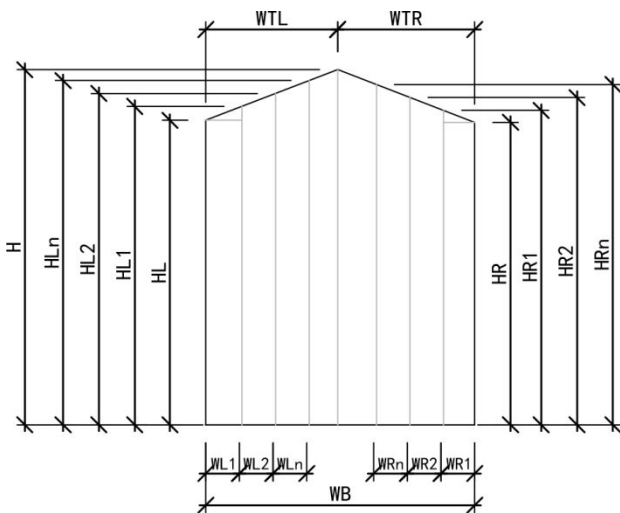

Triangle :

Measurement points: See picture(left)

Measurement: Take

WB/WTL/WTR/H/HL/HR

WL1 match HL1, WL2 match HL2, WLn
match HLn

WR1 match HR1, WR2 match HR2, WRn
match HRn

(Measurement points should be added
supposed the opening is bigger or more
special look)

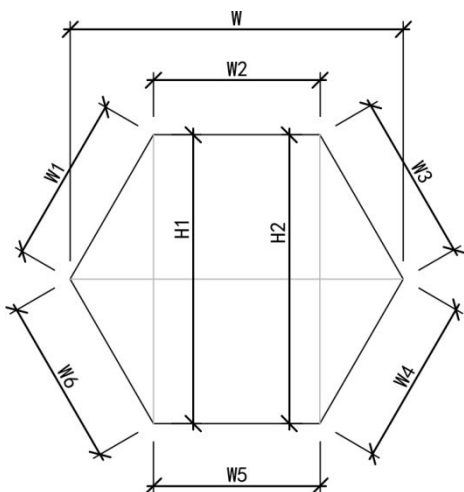

Hexagon:

Measurement points: See picture(left)

Measurement:

Take W/H1/H2/W1/W2/W3/W4/W5/W6

(Measurement points should be added
supposed the opening is bigger or more
special look)

Special shaped opening measurement

By template:

We require an exact copy of the opening profile via cardboard or other sheet. The template should be marked with all the related information, such as width, height, etc. Once the template is received, the factory will begin the production based on the template shape and size ASAP. Please note whether you require deductions to be made or not. The rest of the work will be carried out by the factory. Please allow extra posting time and allow for additional cost.

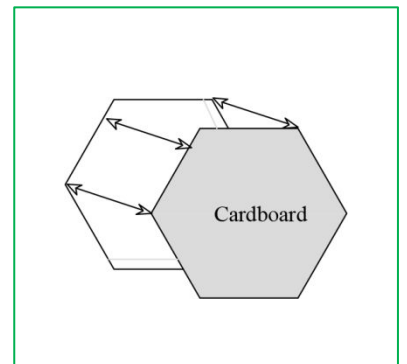
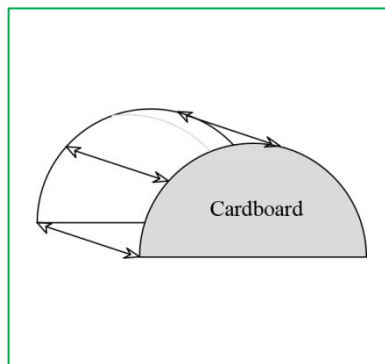
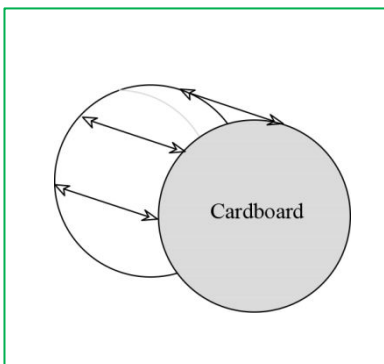
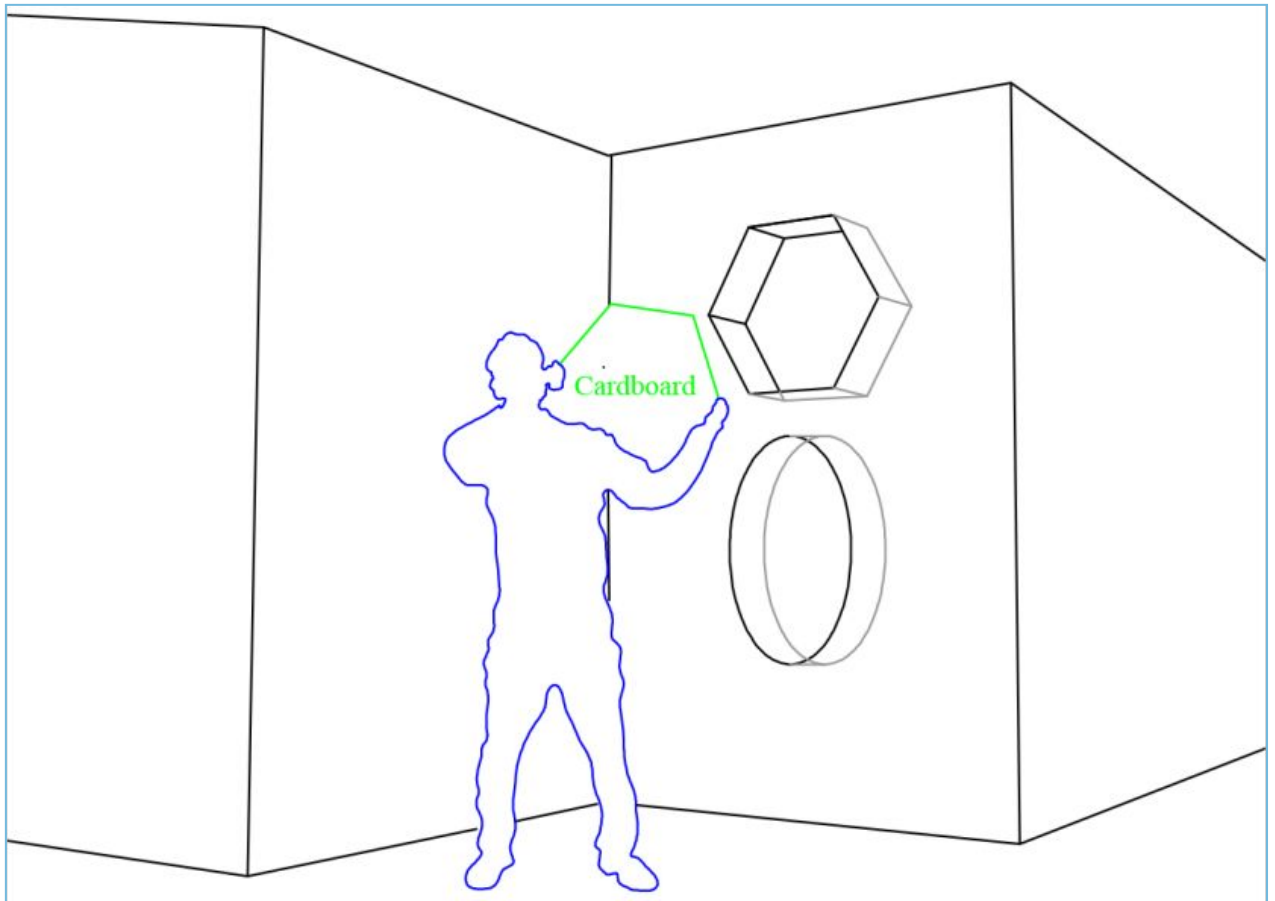

Frame Options

(Front view)

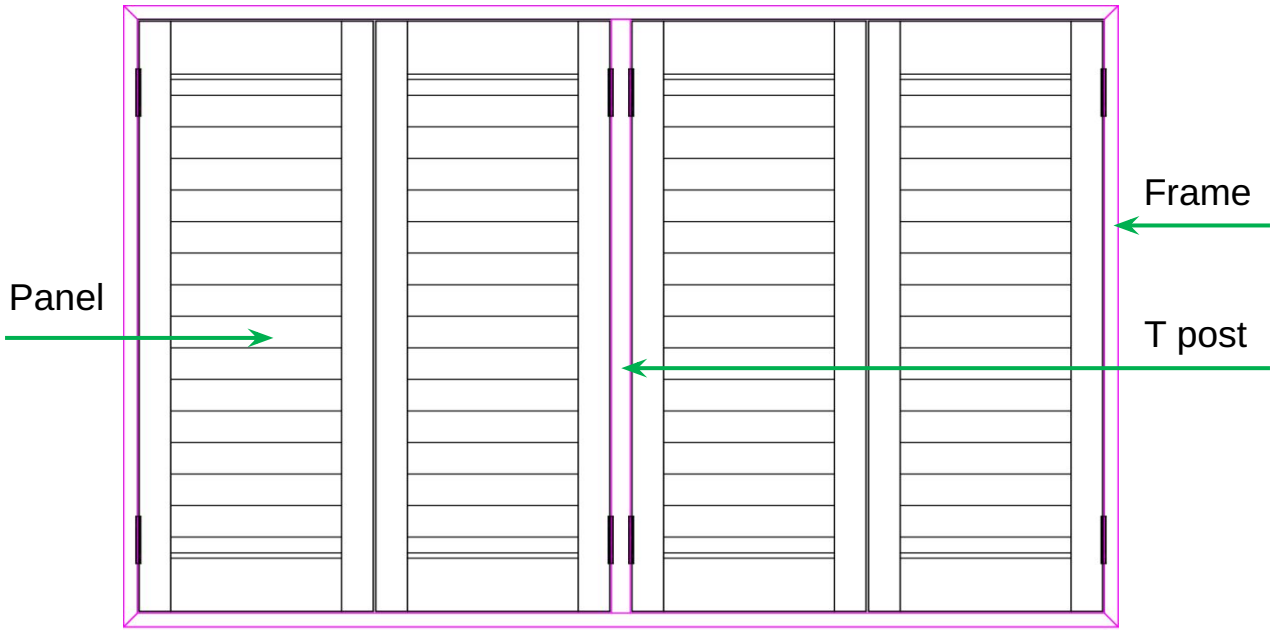

(Top view)



(Top view)

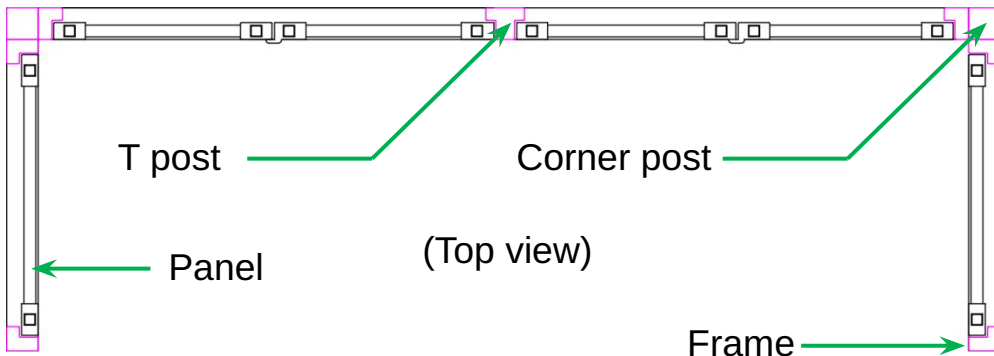

(Top view)

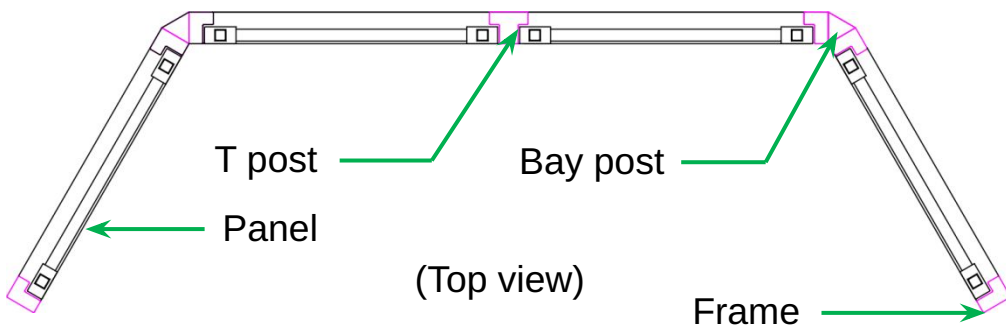

Frame Sides

L stands for left frame, **R** stands for right frame, **T** stands for top frame, **B** stands for bottom frame, **S** stands for bottom closing batten, normally functioning as a bottom frame.

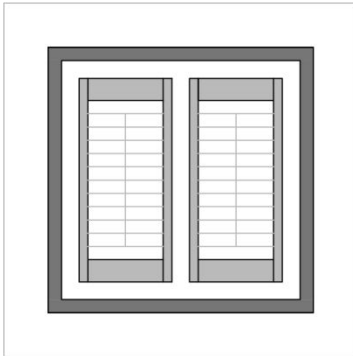

4LRTB
(4 sides)

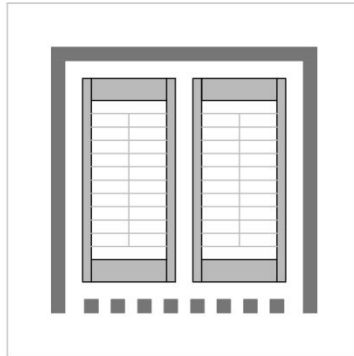

4LRTS
(3 sides with bottom light block)

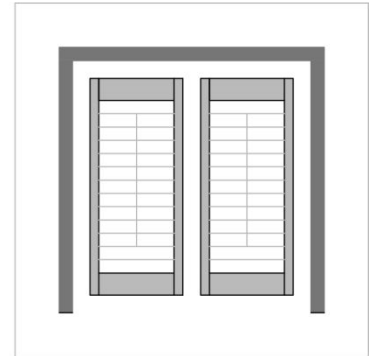

3LRT
(no bottom frame)

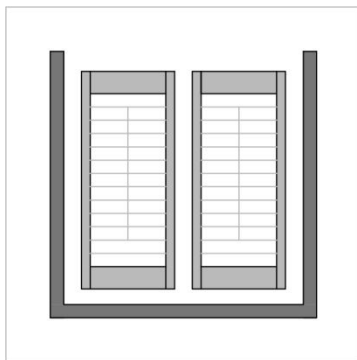

3LRB
(no top frame)

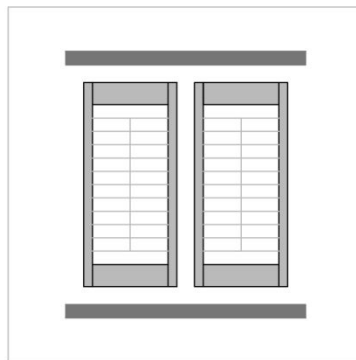

2TB
(top & bottom frame)

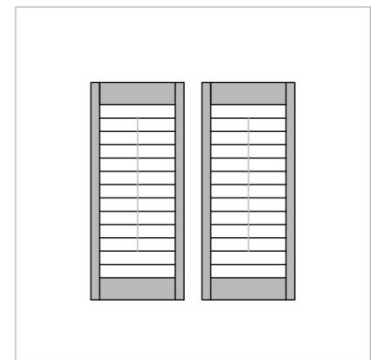

None
(no frame)

Louvre Clearance

Louvre clearance (LC) means the Standard Depth required to make sure all the louvers fully open without touching any obstruction.

Factors that may influence security depth: depth of the opening, frame depth, Protruding depth of the handle, Louver size, Divider location, Rod split location etc.

Inside Mount
(Side view)

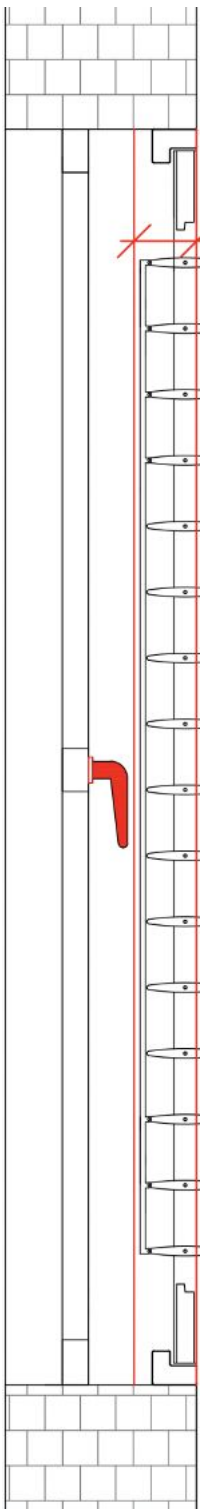

LC

Outside Mount
(Side view)

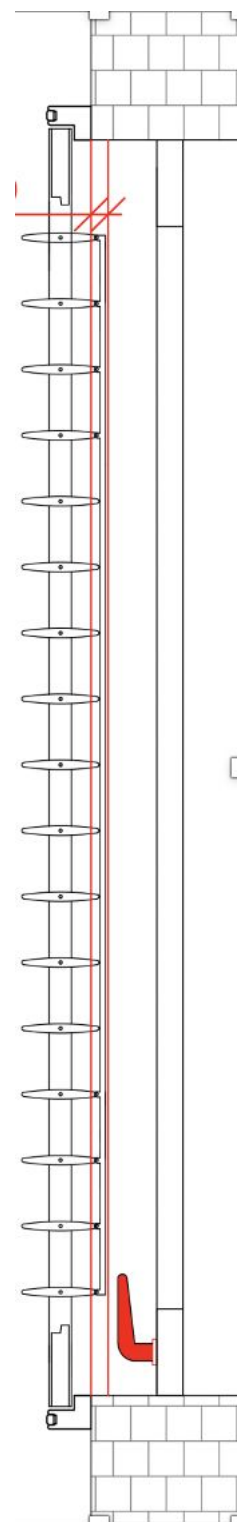

LC

Clearance Required			
Louver	Clearview	Center rod	Invisible Tilt
63.5	56	46	46
88.9	68	58	58
114.3	81	71	71

Measurement of T Posts

Inside mount: Measurement starts from the left of the opening to the center point of each T post.

Outside mount: Measurement starts from the left of the frame to the center point of each T post.

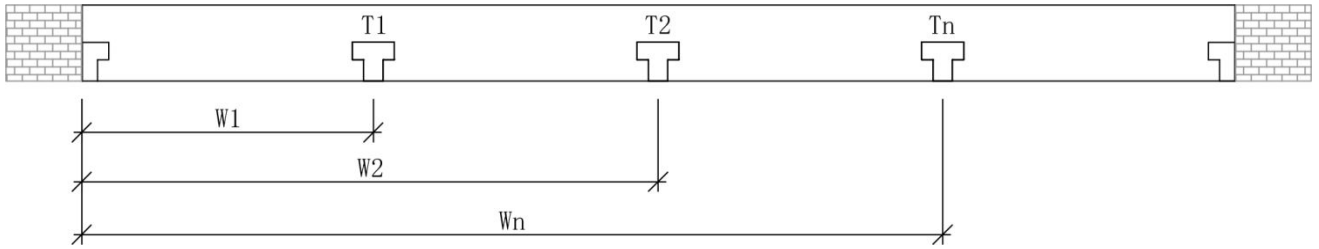

Inside mount of L frame: Measurement starts from the left of the opening to T1, T2, Tn, that is W1, W2, Wn.

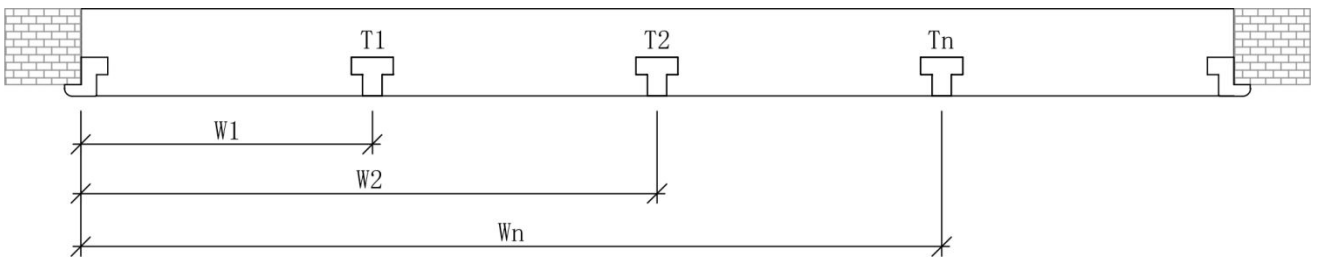

Inside mount of Z frame: Measurement starts from the left of the opening to T1, T2, Tn, that is W1, W2, Wn.

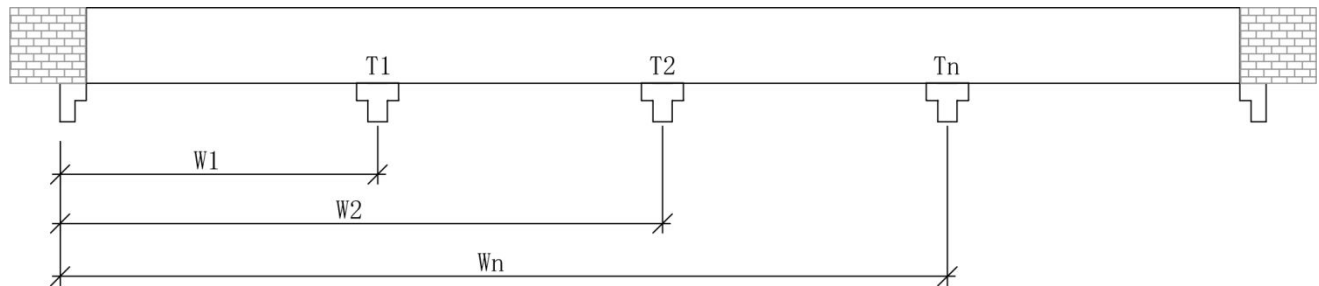

Outside mount of L frame: Measurement starts from the left of the frame to T1, T2, Tn, that is W1, W2, Wn.

Measurement of C Posts

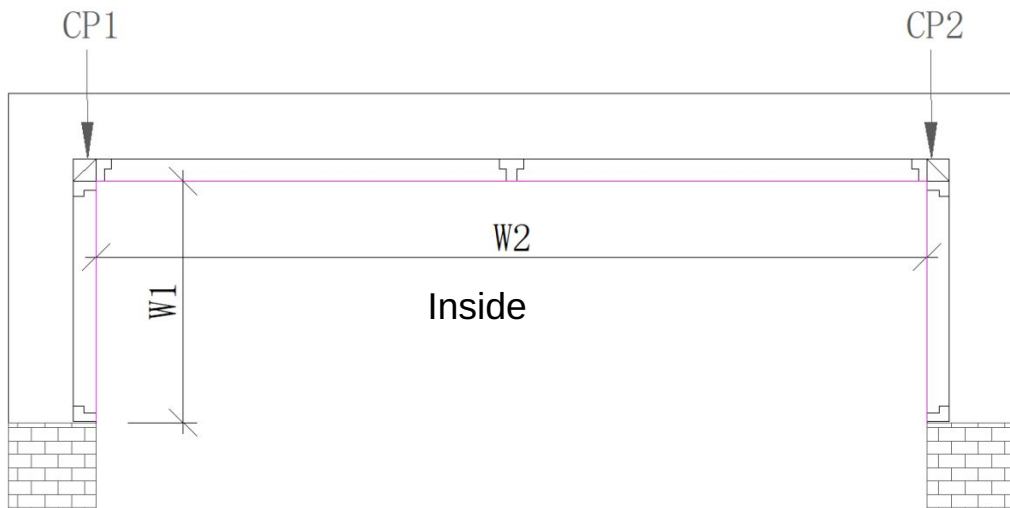

Measurement of corner post: When the mount type is “inside”, it is measured from the left of the opening to the center point of each corner post. See CP1/CP2, that is $W1+W2+W3$. **The width provided on the order form is the sum of the three sides.**

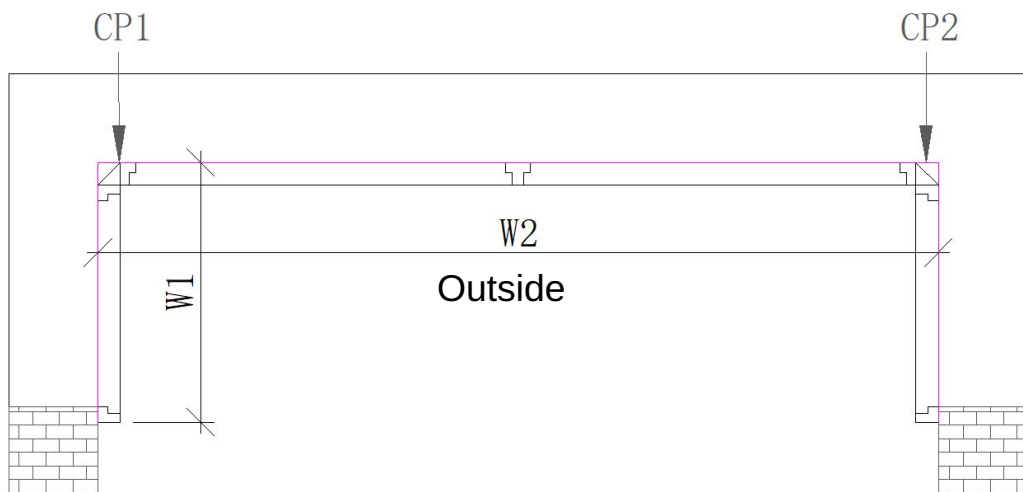

Measurement of corner post: When the mount type is “Outside”, it is measured from the left of the frame to the center point of each corner post. See CP1/CP2, that is $W1+W2+W3$. **The width provided on the order form is the sum of the three sides.**

Measurement of B Posts

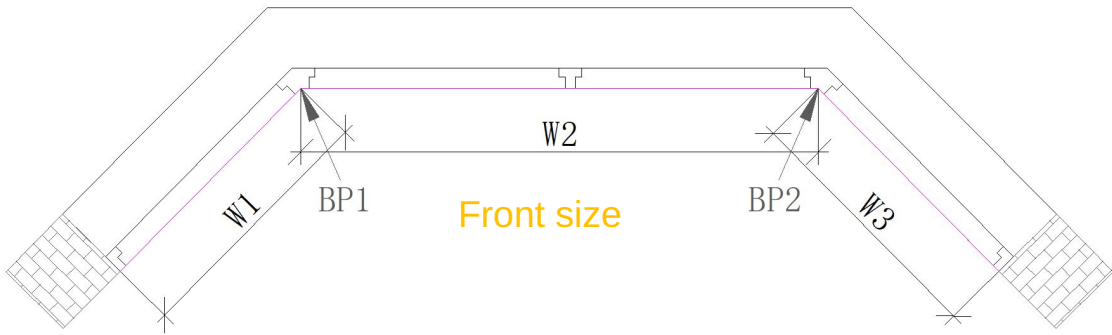

Measurement of bay post :When the mount type is "Inside", it is measured from the left of the opening to the center point of each bay post. See BP1/BP2. **The width provided on the order form is the sum of the three sides,** that is $W1+W2+W3$

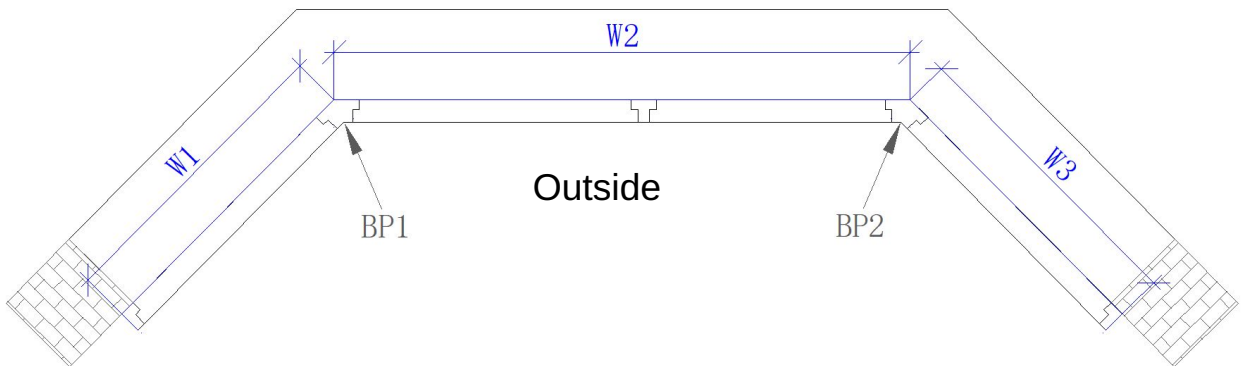

Measurement of bay post :When the mount type is "Outside", it is measured from the left of the frame to the center point of each bay post. See BP1/BP2. **The width provided on the order form is the sum of the three sides,** that is $W1+W2+W3$



Layout Configurations

Hinged Systems:

L = the panels are hinged on the left

R = the panels are hinged on the right

D = D-mould. e.g. L-DR (D Mould attached to right hand panel so right closes over left).

T = T Post. Always measured from the left to the centre of the post.

C = Corner post

B = Bay post

Bi-Fold Systems:

LL = Panel are stacking to the left. E.g. LL-RR (2 panels left, 2 panels right)

RR = Panels are stacking to the right

Sliding Systems:

B = Panel on Back track working from the left. E.g. BFB is Back, Front, Back

F = Panel on Front tracks working left to right

Layouts - Hinged

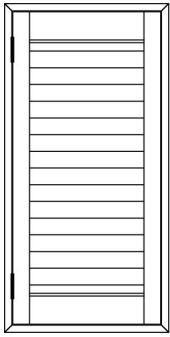

L

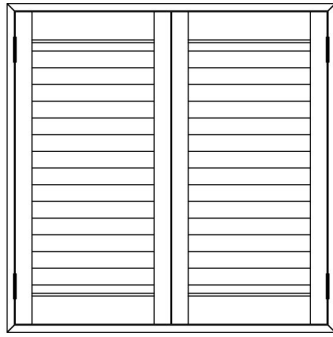
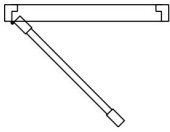

L-DR

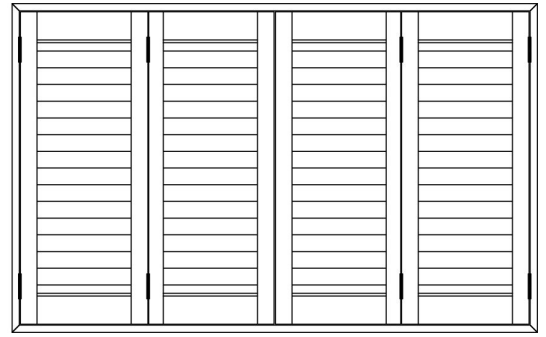
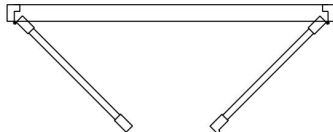

LL-DRR

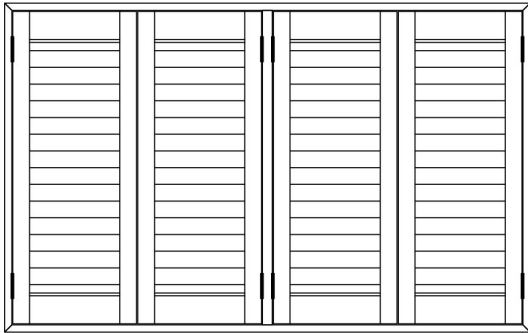
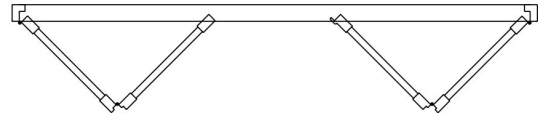

L-DR T L-DR

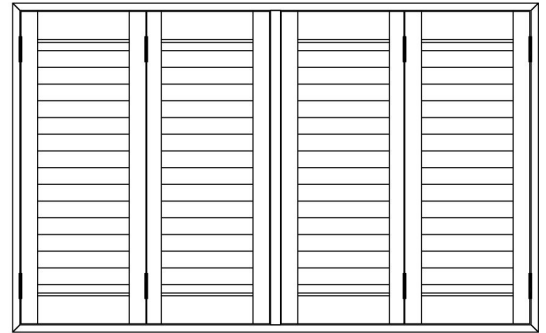
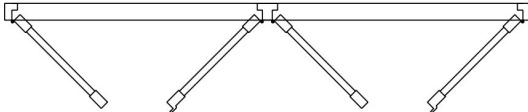

LL T RR

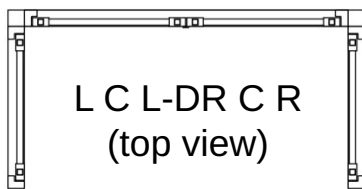
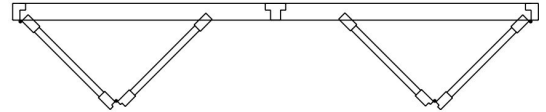

L C L-DR C R
(top view)

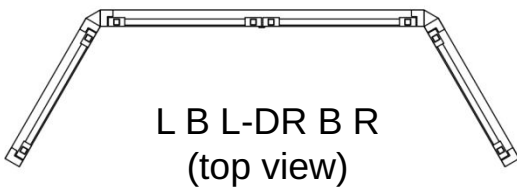

L B L-DR B R
(top view)

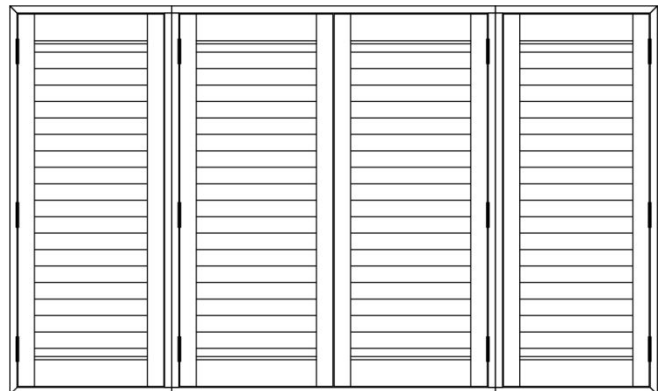

L C L-DR C R / L B L-DR B R

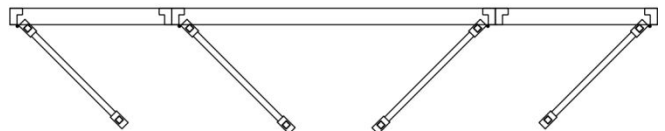

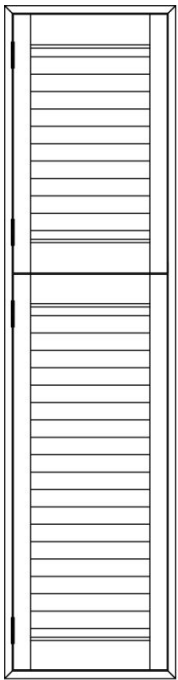

L

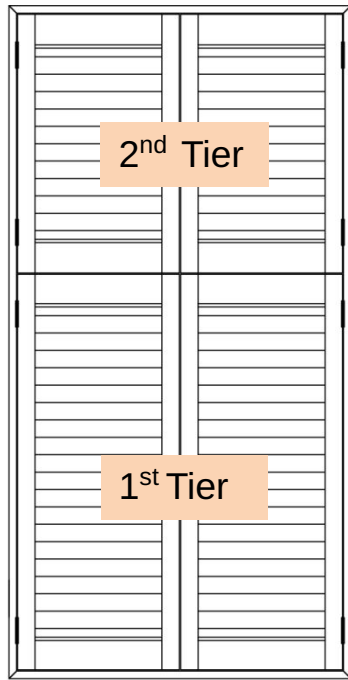
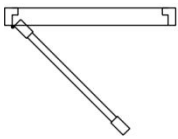

2nd Tier

1st Tier

L-DR

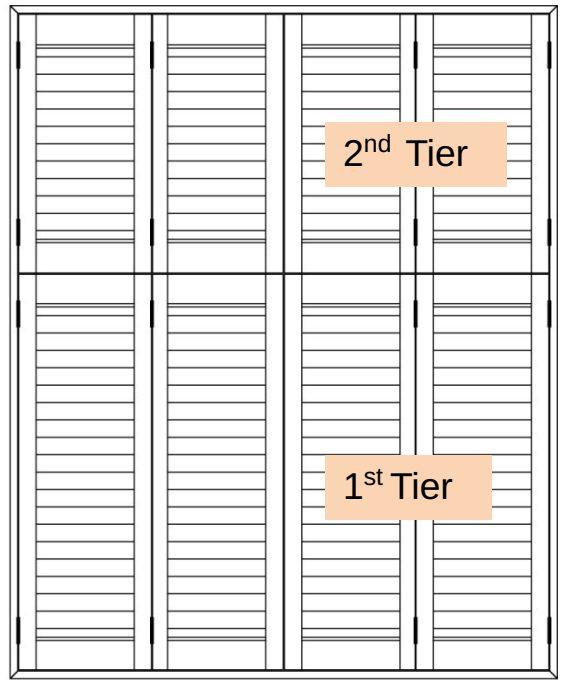
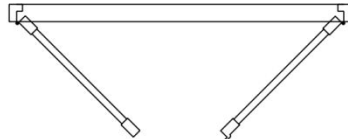

2nd Tier

1st Tier

LL-DRR



2nd Tier

1st Tier

L-DR T L-DR

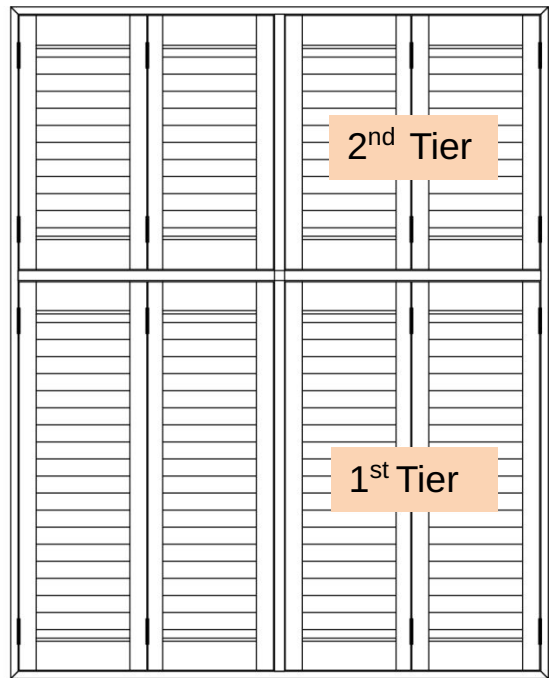
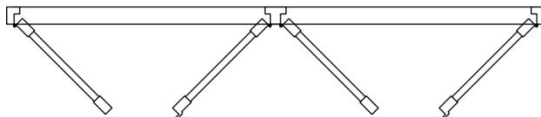

2nd Tier

1st Tier

LLT RR

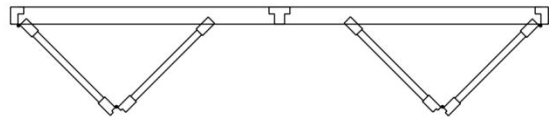



Track Systems

Layouts - Bi-fold Track System

(side view)

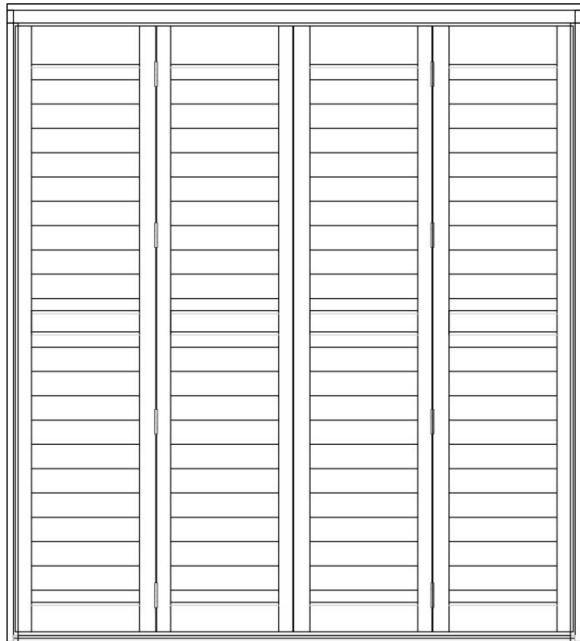

LLRR

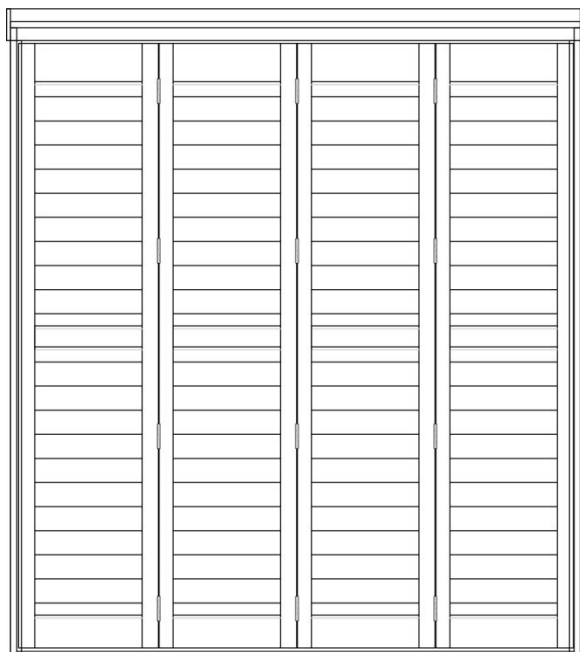

LLLL

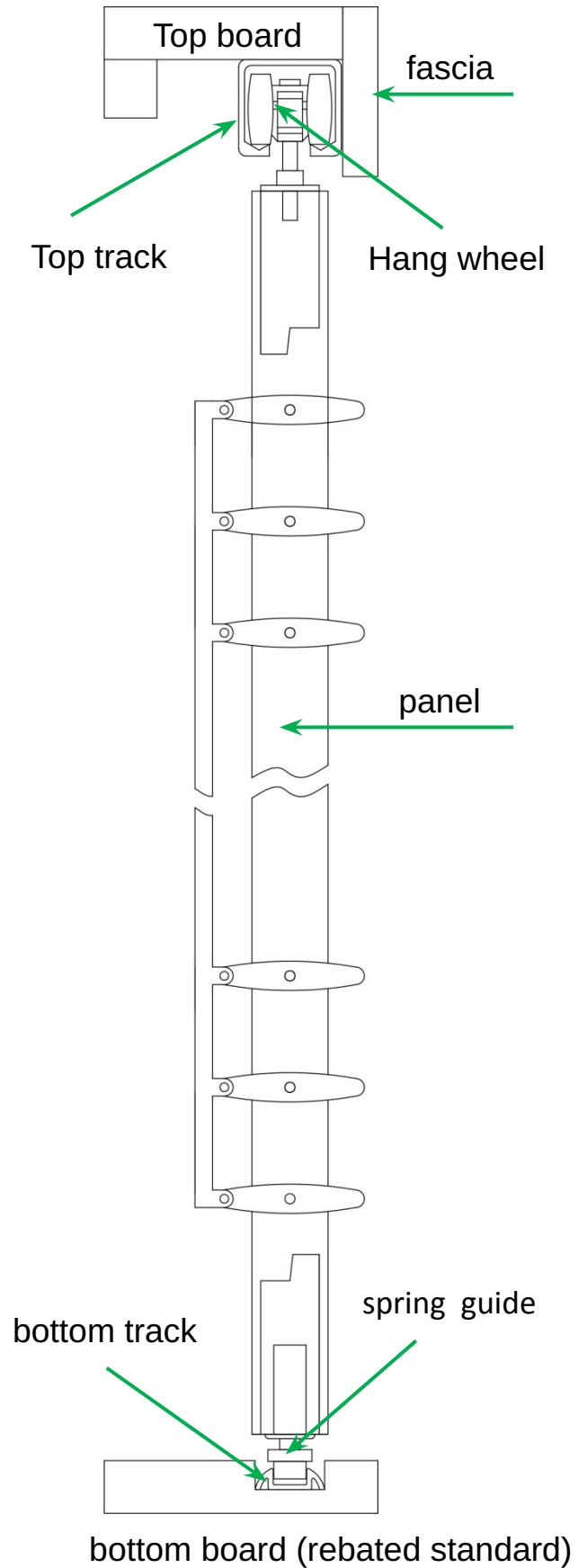
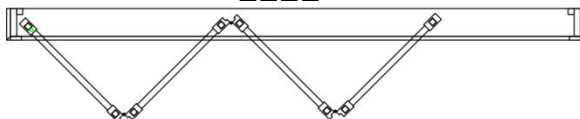

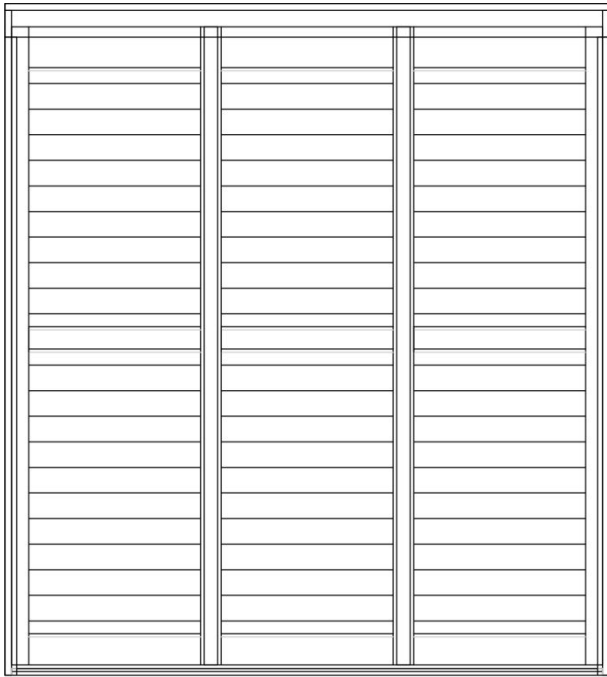

use B to represent back while using F to represent front, showing which panels slide on the front track and which panels slide on the back track.

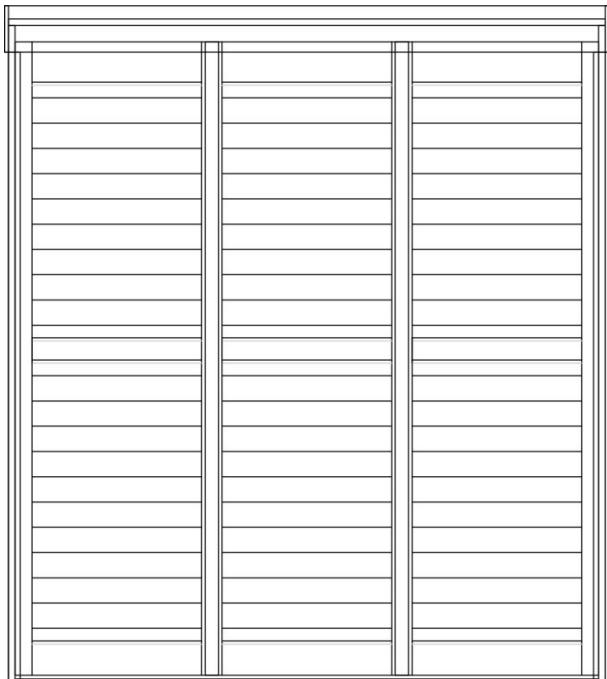

(side view)

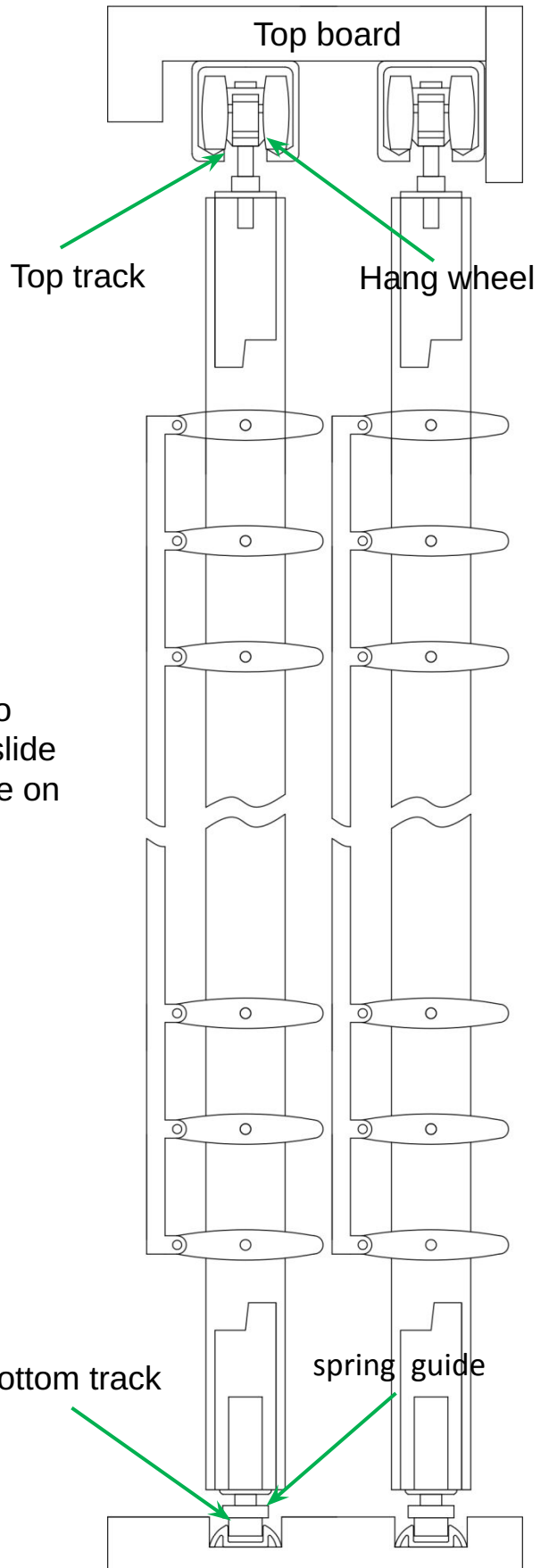

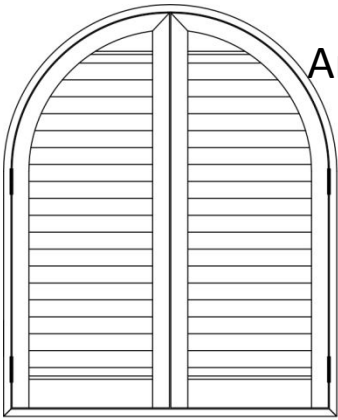

Arch

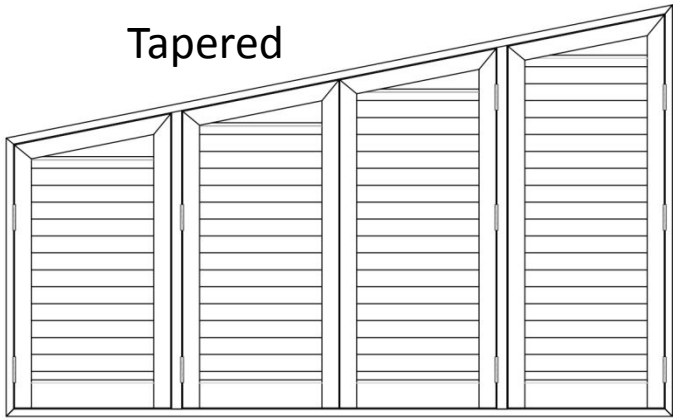

Tapered

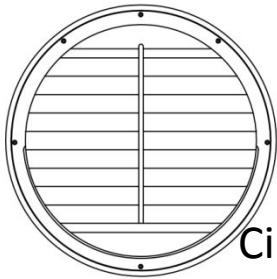
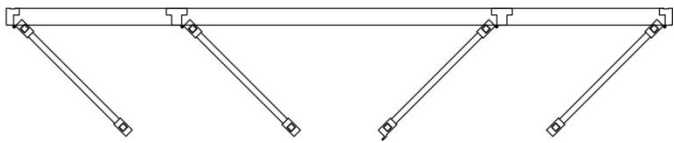
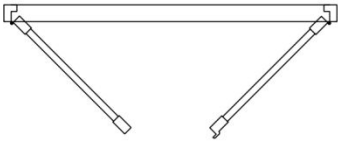

Circle

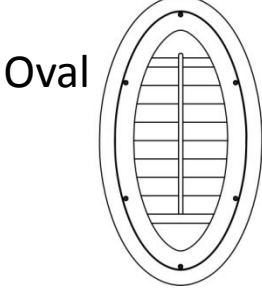

Oval

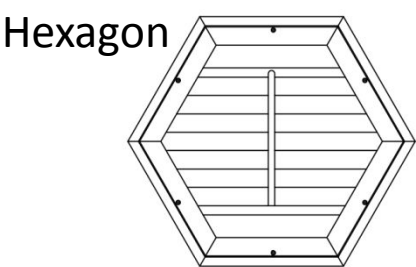

Hexagon

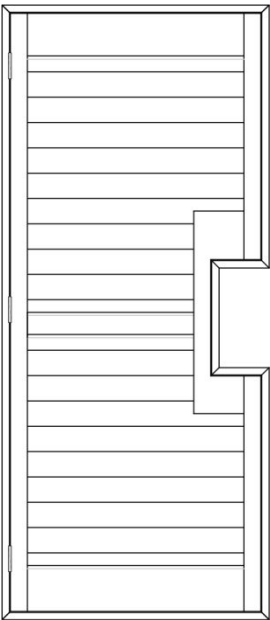

French Door

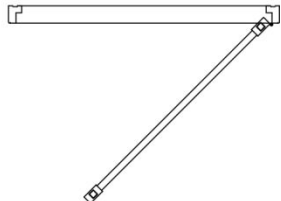
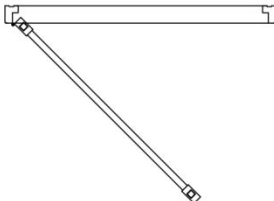
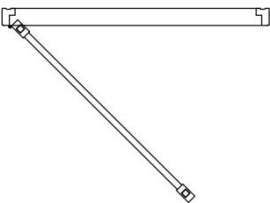
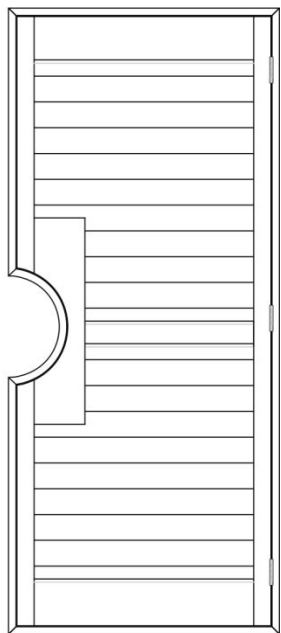
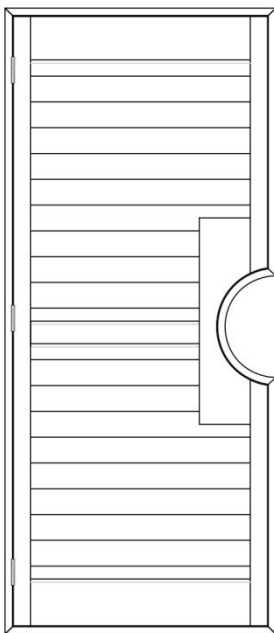

Mount Type

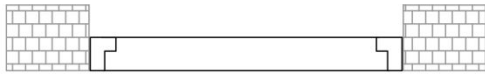

Inside mount

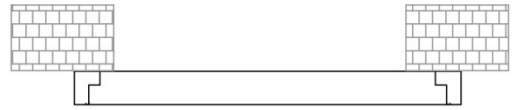

Outside mount



Inside mount

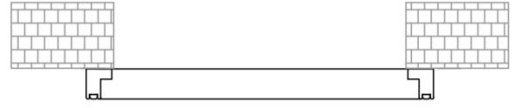

Outside mount

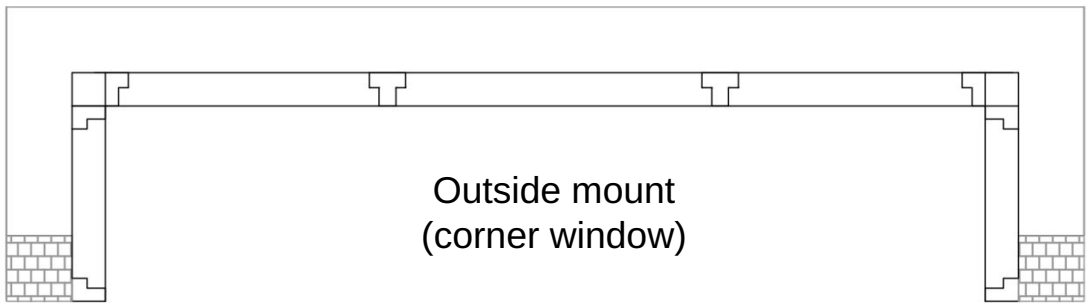

Outside mount
(corner window)

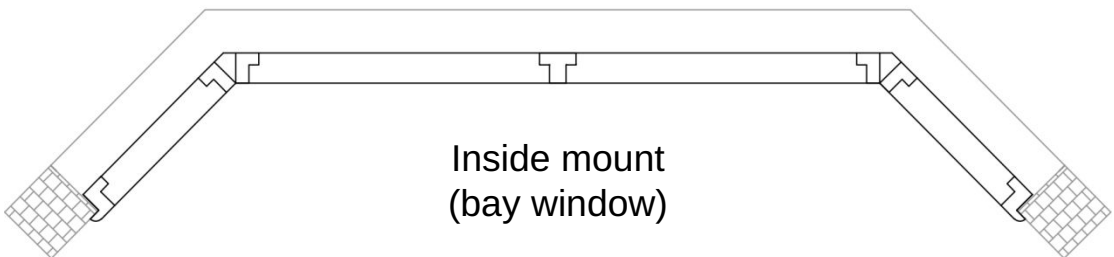

Inside mount
(bay window)



(track bi-fold)

Inside mount

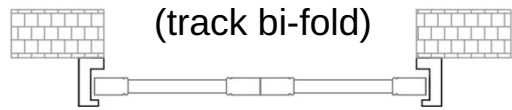

(track bi-fold)

Outside mount

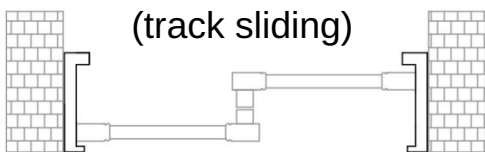

(track sliding)

Inside mount

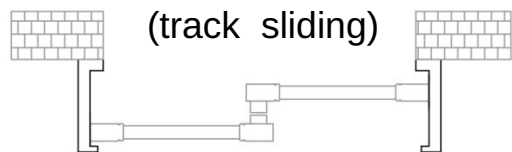

(track sliding)

Outside mount

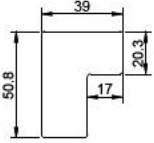
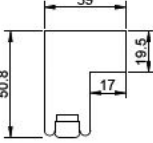
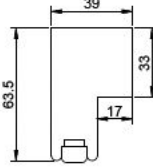
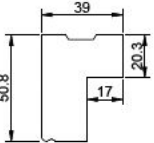
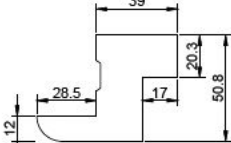
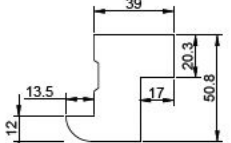
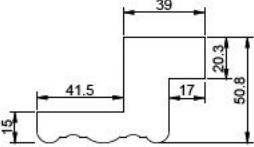
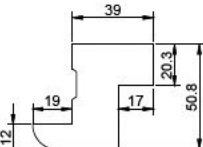
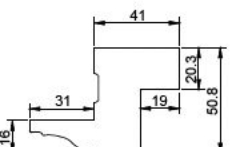
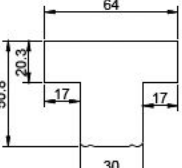
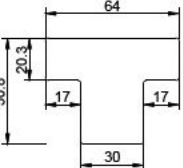
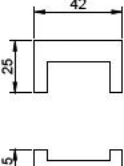
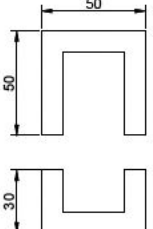

Betta Poly & Betta Hybrid Components

 <p>Betta Poly Flat L</p>	 <p>Betta Poly FFL50</p>	 <p>Betta Poly FFL63.3</p>
 <p>Betta Poly Standard L</p>	 <p>Betta Poly Standard Z</p>	 <p>Betta Poly Small Z</p>
 <p>Betta Poly Crown Z</p>	 <p>Betta Poly Medium Z</p>	 <p>Betta Poly Deco Z</p>
 <p>Betta Poly Beaded T Post</p>		 <p>Betta Poly Flat T Post</p>
 <p>Betta Poly U Channel A</p>		 <p>Betta Poly U Channel B</p>

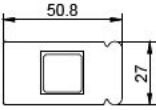
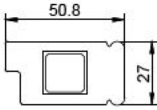
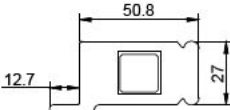
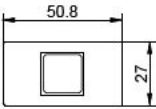
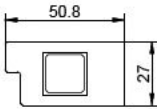
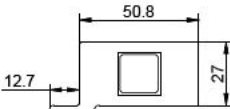
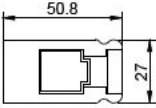
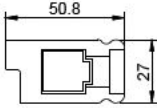
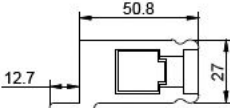
 <p>BettaPoly1102A0 PVC reinforced square stile</p>	 <p>BettaPoly1104A0 PVC reinforced rabate stile</p>	 <p>BettaPoly1106A0 PVC reinforced D-stile</p>
 <p>BettaPoly1101A0 PVC reinforced flat square stile</p>	 <p>BettaPoly1103A0 PVC reinforced flat rabate stile</p>	 <p>BettaPoly1105A0 PVC reinforced flat D-stile</p>
 <p>BettaPoly1202A0 only for Rod in stile</p>	 <p>BettaPoly1204A0 only for Rod in stile</p>	 <p>BettaPoly1206A0 only for Rod in stile</p>

Betta Poly Louvers

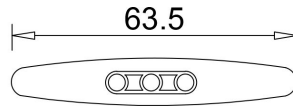

PVC64R
63.5mm Reinforced Louver

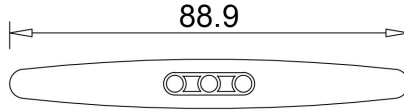

PVC89R
88.9mm Reinforced Louver

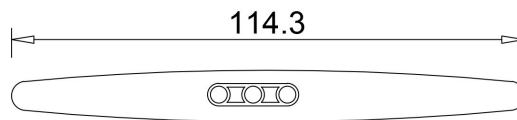

PVC114R
114.3mm Reinforced Louver

Betta Hybrid Louvers

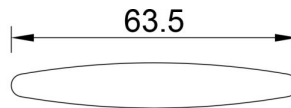

BAS64S
63.5mm Louver

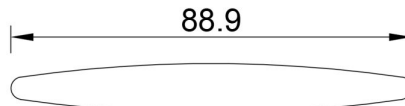

BAS89S
88.9mm Louver

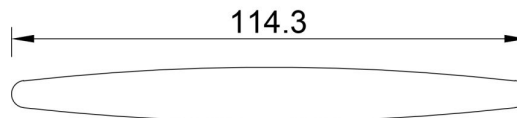

BAS114S
114.3mm Louver

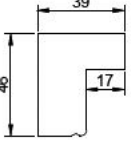
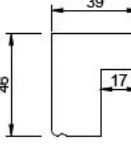
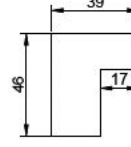
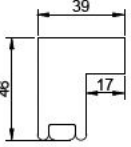
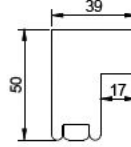
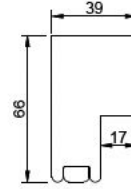
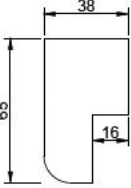
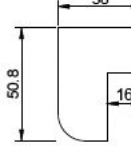
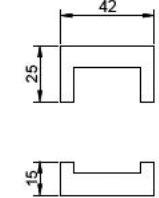
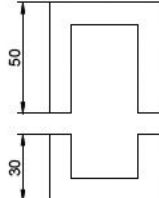
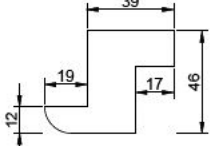
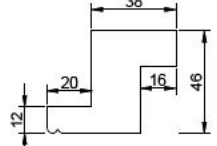
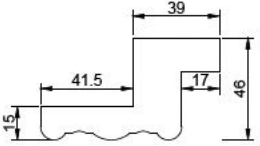
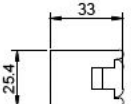
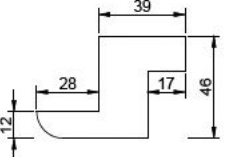
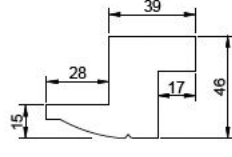
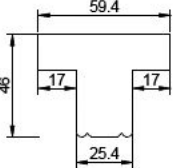
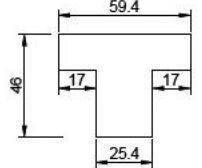

**Betta Basswood
& Betta Paulownia
Components**

 <p>Bettabasswood BL01</p>	 <p>Bettabasswood BL02</p>	 <p>Bettabasswood FL01</p>	
 <p>Bettabasswood BCL01</p>	 <p>Bettabasswood M-BCL01</p>	 <p>Bettabasswood H-BCL01</p>	
 <p>Bettabasswood FL03A</p>	 <p>Bettabasswood FL03B</p>	 <p>Bettabasswood U Channel A</p>	 <p>Bettabasswood U Channel B</p>
 <p>Bettabasswood Standard Z</p>	 <p>Bettabasswood Flat Z</p>	 <p>Bettabasswood Crown Z</p>	 <p>Bettabasswood Hang Strip</p>
 <p>Bettabasswood Large Z</p>	 <p>Bettabasswood Deco Z</p>	 <p>Bettabasswood Beaded T Post</p>	 <p>Bettabasswood Flat T Post</p>

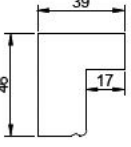
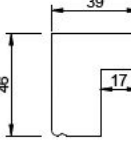
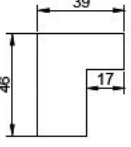
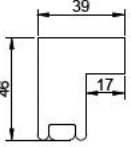
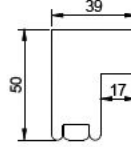
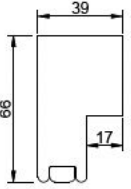
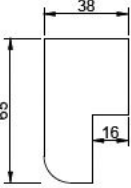
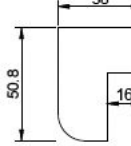
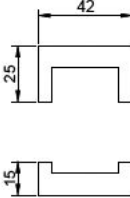
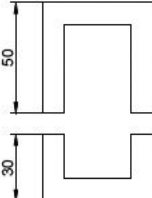
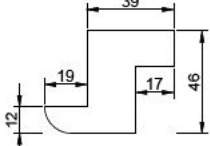
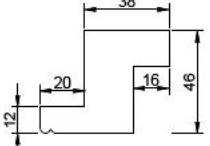
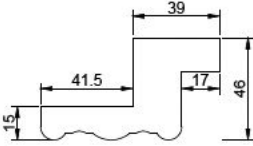
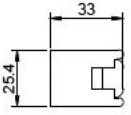
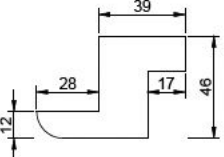
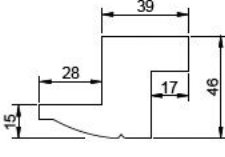
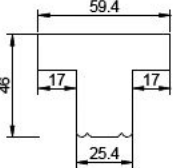
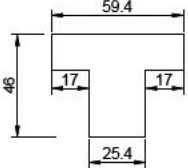
 <p>Bettapaulownia BL01</p>	 <p>Bettapaulownia BL02</p>	 <p>Bettapaulownia FL01</p>	
 <p>Bettapaulownia BCL01</p>	 <p>Bettapaulownia M-BCL01</p>	 <p>Bettapaulownia H-BCL01</p>	
 <p>Bettapaulownia FL03A</p>	 <p>Bettapaulownia FL03B</p>	 <p>Bettapaulownia U Channel A</p>	 <p>Bettapaulownia U Channel B</p>
 <p>Bettapaulownia Standard Z</p>	 <p>Bettapaulownia Flat Z</p>	 <p>Bettapaulownia Crown Z</p>	 <p>Bettapaulownia Hang Strip</p>
 <p>Bettapaulownia Large Z</p>	 <p>Bettapaulownia Deco Z</p>	 <p>Bettapaulownia Beaded T Post</p>	 <p>Bettapaulownia Flat T Post</p>

Shutter Imported Timber Stiles

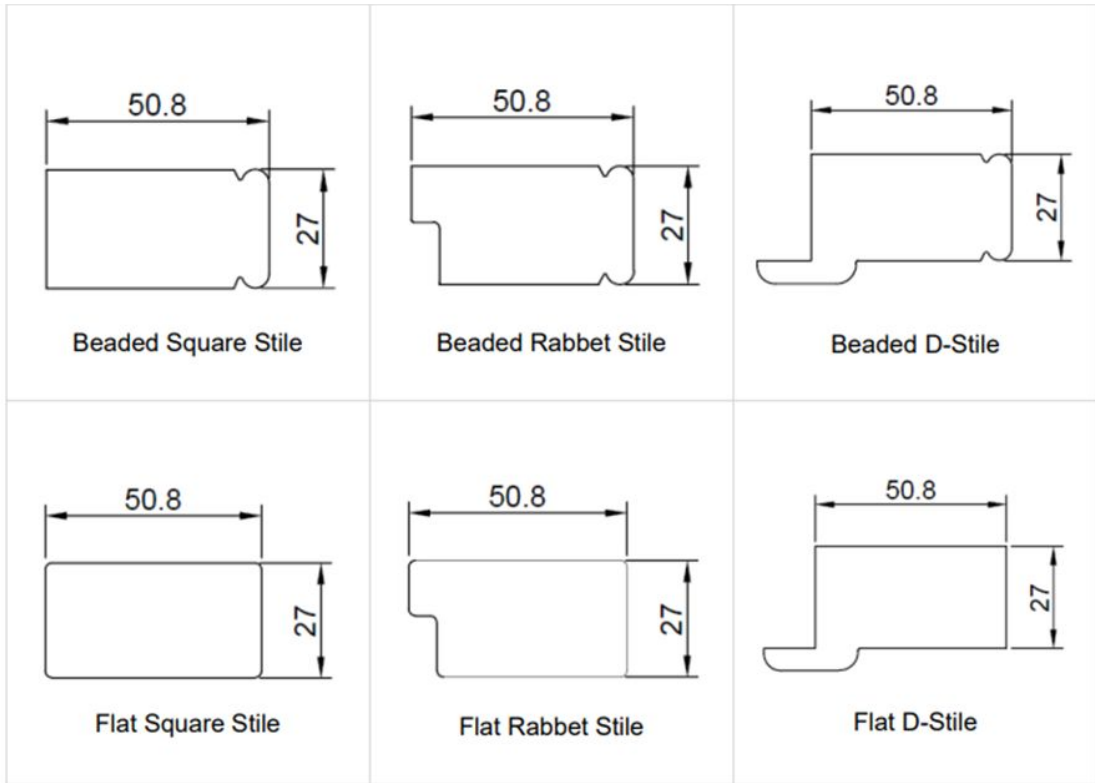

Betta Basswood Louvres

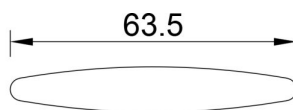

BAS64S
63.5mm Louver

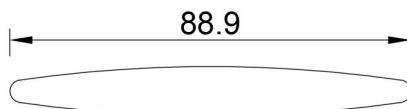

BAS89S
88.9mm Louver

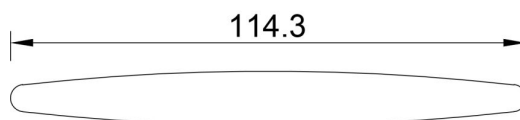

BAS114S
114.3mm Louver



Clearances & Tracking Systems

IMPORTANT NOTE

When measuring for outside mount track systems, the order size is to the **outside** of the side boards and the **top** of the head board!

i.e. If you have measured from architrave to architrave and floor to top of architrave. Unless you are fitting directly on to the architrave, you need to add the following to your dimensions:

80mm to your architrave width and 40mm to height!

Overall Size

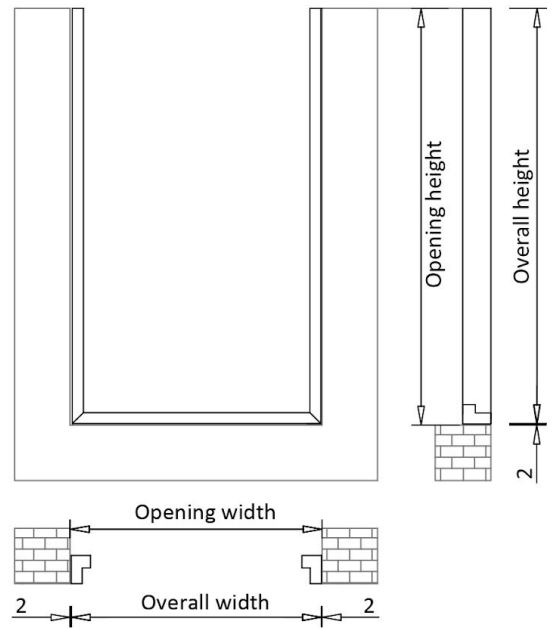
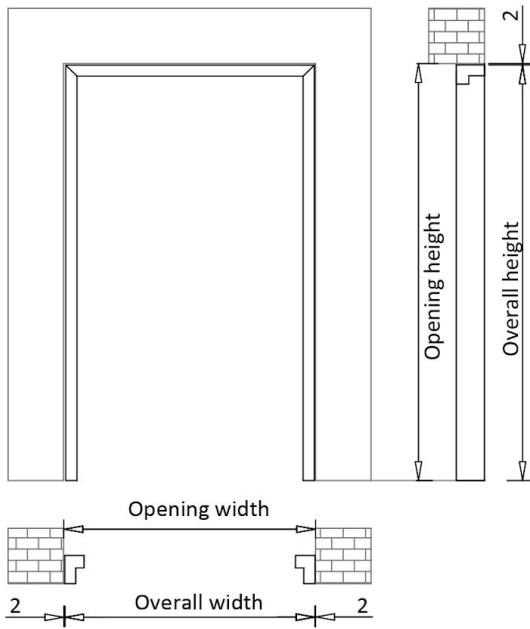

Frame type:	L shaped frame	Frame sides:	3LRT
Hardware:	/	Installation:	Mount in
Overall height:	= Opening height-2		
Overall width:	= Opening width -2-2		

Frame type:	L shaped frame	Frame sides:	3LRB
Hardware:	/	Installation:	Mount in
Overall height:	= Opening height-2		
Overall width:	= Opening width -2-2		

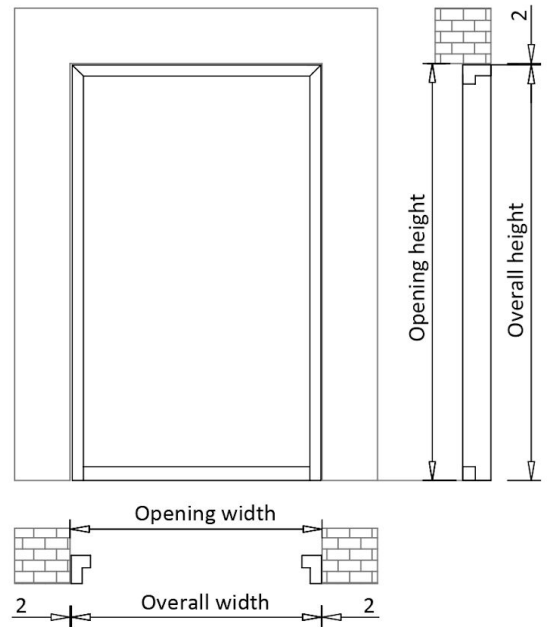
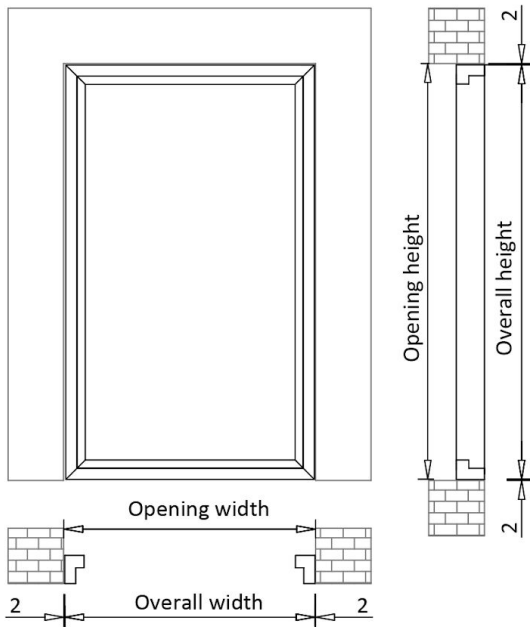

Frame type:	L shaped frame	Frame sides:	4LRTB
Hardware:	/	Installation:	Mount in
Overall height:	= Opening height-2-2		
Overall width:	= Opening width -2-2		

Frame type:	L shaped frame	Frame sides:	4LRTS
Hardware:	/	Installation:	Mount in
Overall height:	= Opening height-2		
Overall width:	= Opening width -2-2		

Overall Size

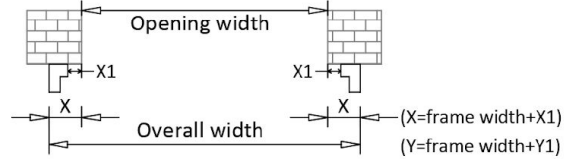
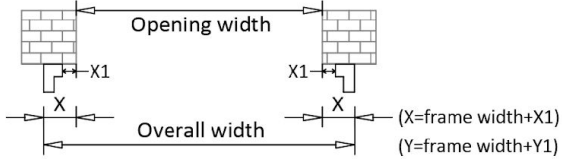
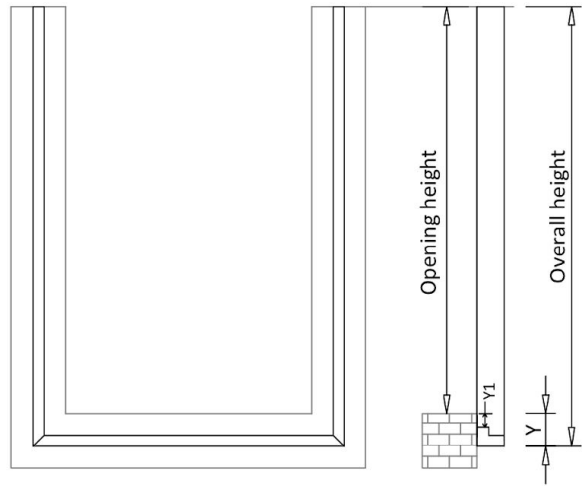
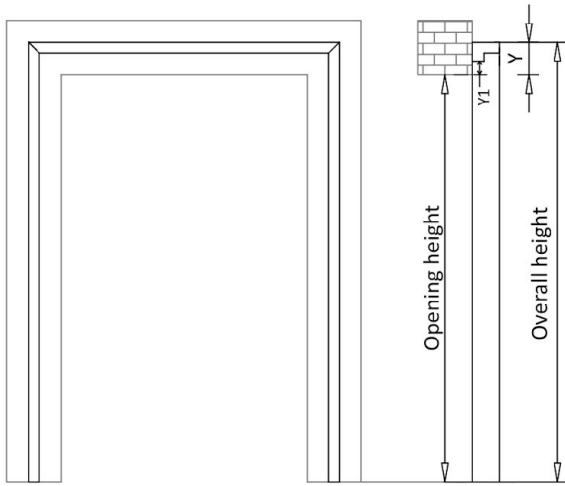

Frame type:	L shaped frame	Frame sides:	3LRT
Hardware:	/	Installation:	Mount out
Overall height:	= Opening height+Y		
Overall width:	= Opening width +X+X		

Frame type:	L shaped frame	Frame sides:	3LRB
Hardware:	/	Installation:	Mount out
Overall height:	= Opening height+Y		
Overall width:	= Opening width +X+X		

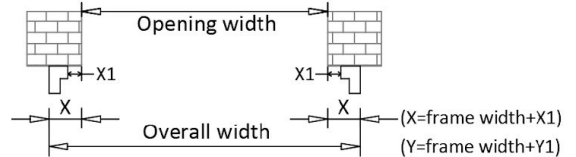
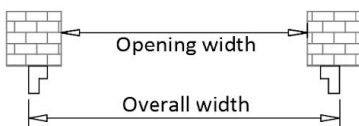
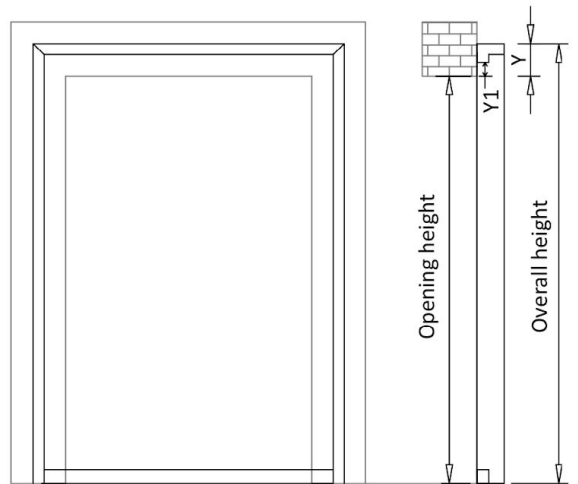
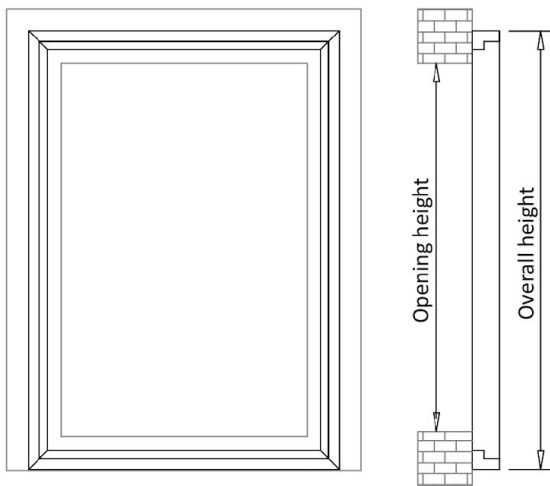

Frame type:	L shaped frame	Frame sides:	4LRTB
Hardware:	/	Installation:	Mount out
Overall height:	= Opening height+Y+Y		
Overall width:	= Opening width +X+X		

Frame type:	L shaped frame	Frame sides:	4LRTS
Hardware:	/	Installation:	Mount out
Overall height:	= Opening height+Y		
Overall width:	= Opening width +X+X		

Overall Size

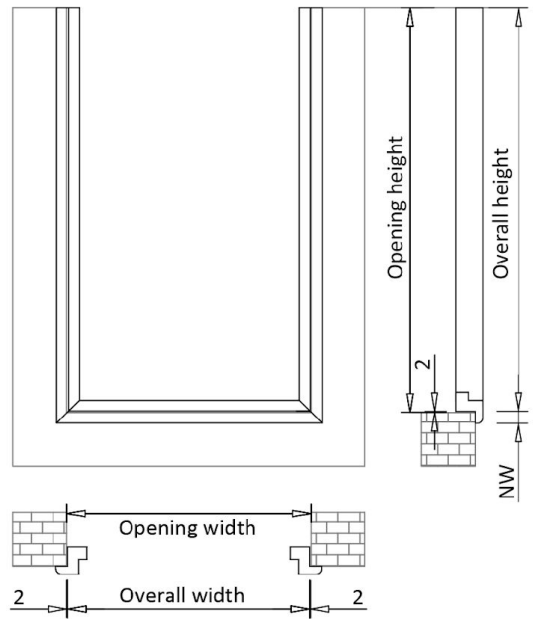
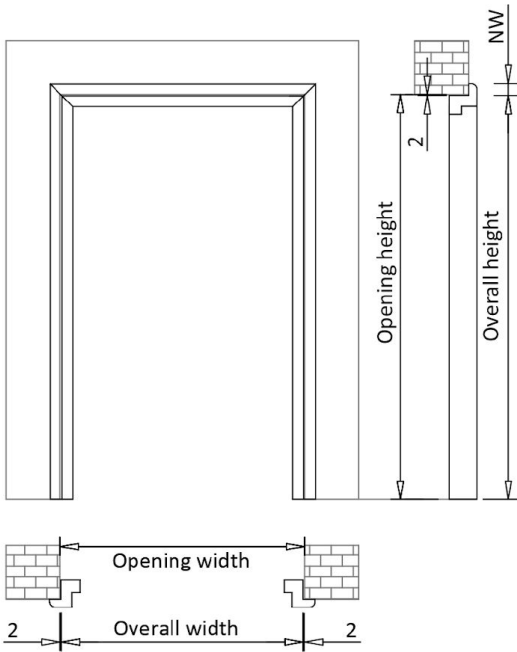

Frame type:	Z shaped frame	Frame sides:	3LRT
Hardware:	/	Installation:	Mount in
Overall height:	= Opening height-2		
Overall width:	= Opening width -2-2		
Please note the nose width (NW) outside the wall			

Frame type:	Z shaped frame	Frame sides:	3LRB
Hardware:	/	Installation:	Mount in
Overall height:	= Opening height-2		
Overall width:	= Opening width -2-2		
Please note the nose width (NW) outside the wall			

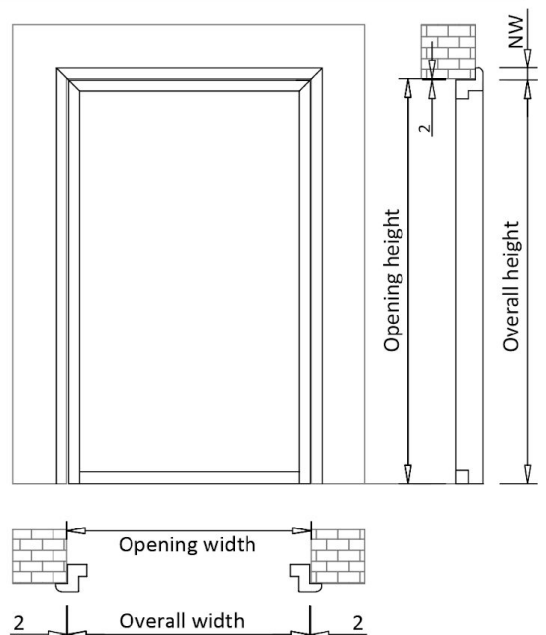
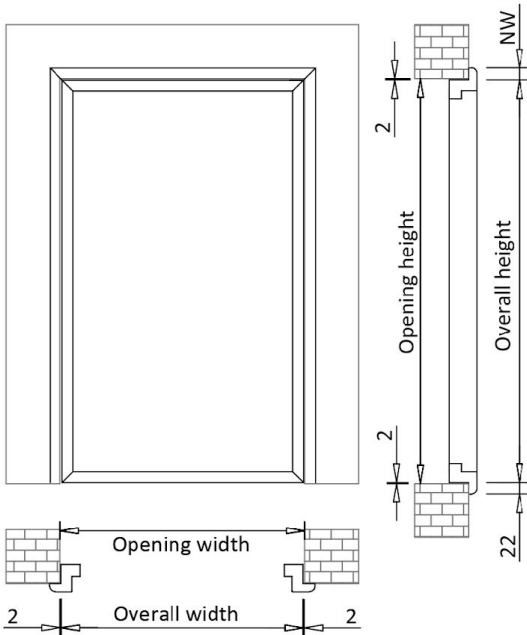

Frame type:	Z shaped frame	Frame sides:	4LRTB
Hardware:	/	Installation:	Mount in
Overall height:	= Opening height-2-2		
Overall width:	= Opening width -2-2		
Please note the nose width (NW) outside the wall			

Frame type:	Z shaped frame	Frame sides:	4LRTS
Hardware:	/	Installation:	Mount in
Overall height:	= Opening height-2		
Overall width:	= Opening width -2-2		
Please note the nose width (NW) outside the wall			

Overall Size

<p>Opening height</p> <p>Overall height=Opening height -2</p>	<p>Opening width</p> <p>Overall width=Opening width-2-2</p> <p>Opening width</p> <p>Overall width=Opening width</p>	<p>Mount in side frames: <u>Yes</u></p> <p>L=the standard depth of frame</p> <table border="1"> <thead> <tr> <th>Louver size</th> <th>depth</th> </tr> </thead> <tbody> <tr> <td>63.5mm</td> <td>90mm</td> </tr> <tr> <td>88.9mm</td> <td>100mm</td> </tr> </tbody> </table> <p>Mount in side frames: <u>no</u></p>	Louver size	depth	63.5mm	90mm	88.9mm	100mm
Louver size	depth							
63.5mm	90mm							
88.9mm	100mm							
<p>Opening height</p> <p>Overall height=Opening height -2</p>	<p>Opening width</p> <p>Overall width=Opening width-2-2</p> <p>Opening width</p> <p>Overall width=Opening width</p>	<p>Semi-mount in side frames: <u>Yes</u></p> <p>L=the standard depth of frame</p> <table border="1"> <thead> <tr> <th>Louver size</th> <th>depth</th> </tr> </thead> <tbody> <tr> <td>63.5mm</td> <td>95mm</td> </tr> <tr> <td>88.9mm</td> <td>100mm</td> </tr> </tbody> </table> <p>Semi-mount in side frames: <u>no</u></p>	Louver size	depth	63.5mm	95mm	88.9mm	100mm
Louver size	depth							
63.5mm	95mm							
88.9mm	100mm							
<p>Opening height</p> <p>Overall height=Opening height +58</p>	<p>Opening width</p> <p>Overall width=Opening width+40+40</p> <p>Opening width</p> <p>Overall width=Opening width+X+X (X<30)</p>	<p>Mount out side frames: <u>Yes</u></p> <p>L=the standard depth of frame</p> <table border="1"> <thead> <tr> <th>Louver size</th> <th>depth</th> </tr> </thead> <tbody> <tr> <td>63.5mm</td> <td>90mm</td> </tr> <tr> <td>88.9mm</td> <td>100mm</td> </tr> </tbody> </table> <p>Mount out side frames: <u>no</u></p>	Louver size	depth	63.5mm	90mm	88.9mm	100mm
Louver size	depth							
63.5mm	90mm							
88.9mm	100mm							

Overall Size

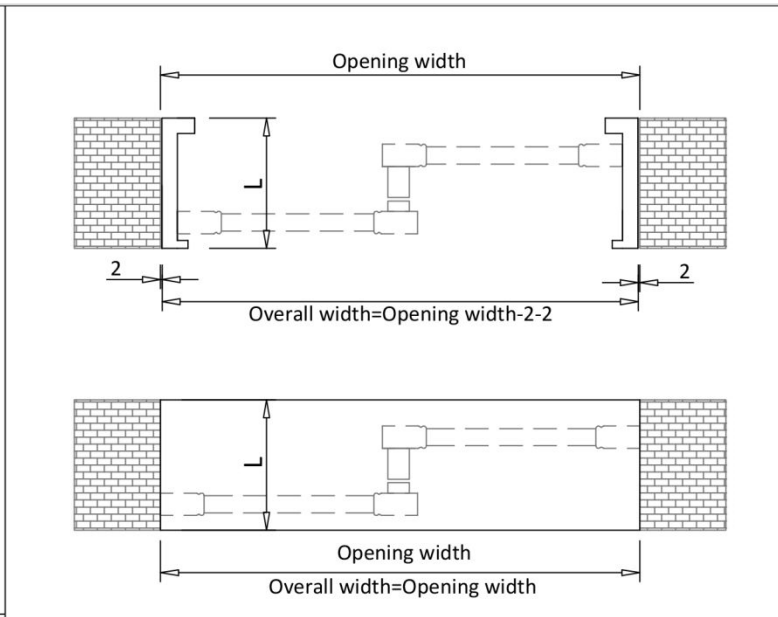
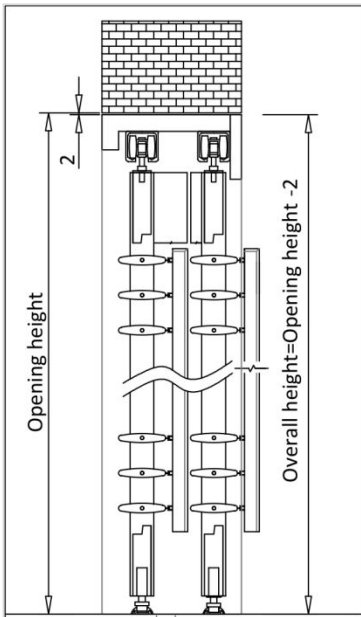

Mount in
side frames: Yes

L=the standard depth of frame

Louver size	depth
63.5mm	180mm
88.9mm	210mm

Mount in
side frames: no

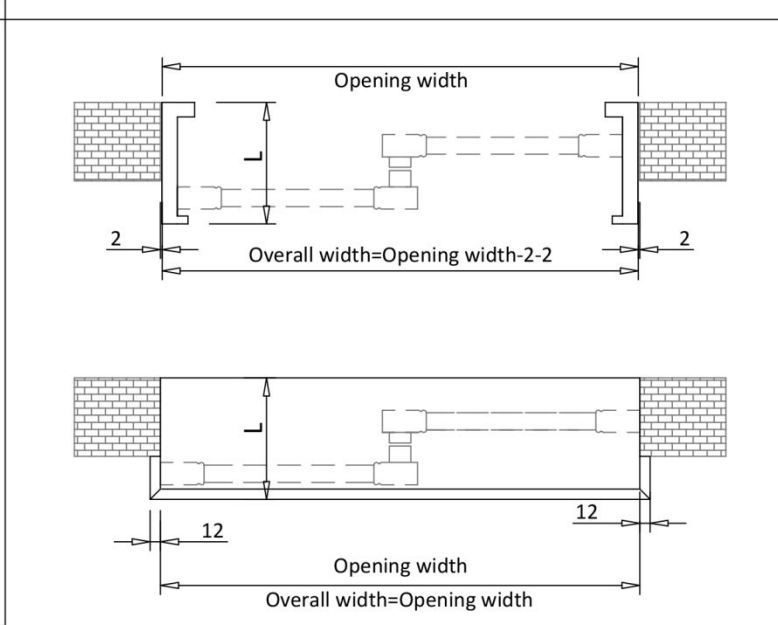
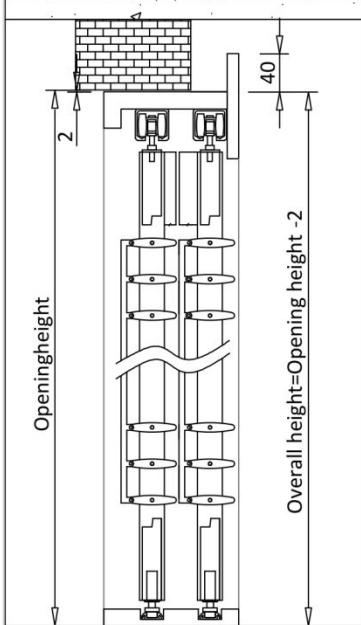

Semi-mount in
side frames: Yes

L=the standard depth of frame

Louver size	depth
63.5mm	180mm
88.9mm	210mm

Semi-mount in
side frames: no

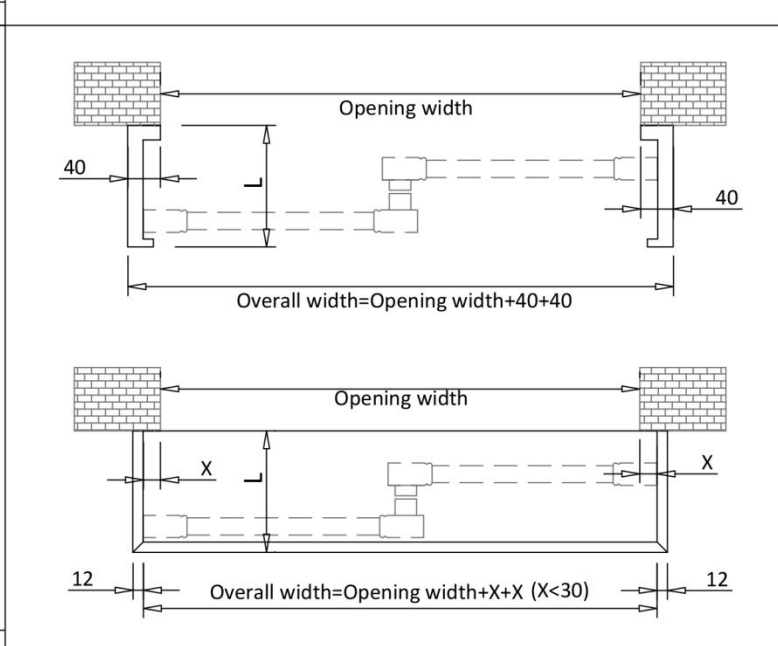
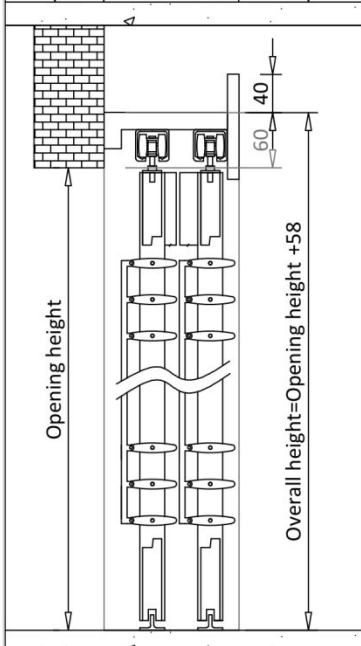

Mount out
side frames: Yes

L=the standard depth of frame

Louver size	depth
63.5mm	180mm
88.9mm	210mm

Mount out
side frames: no

Overall Size

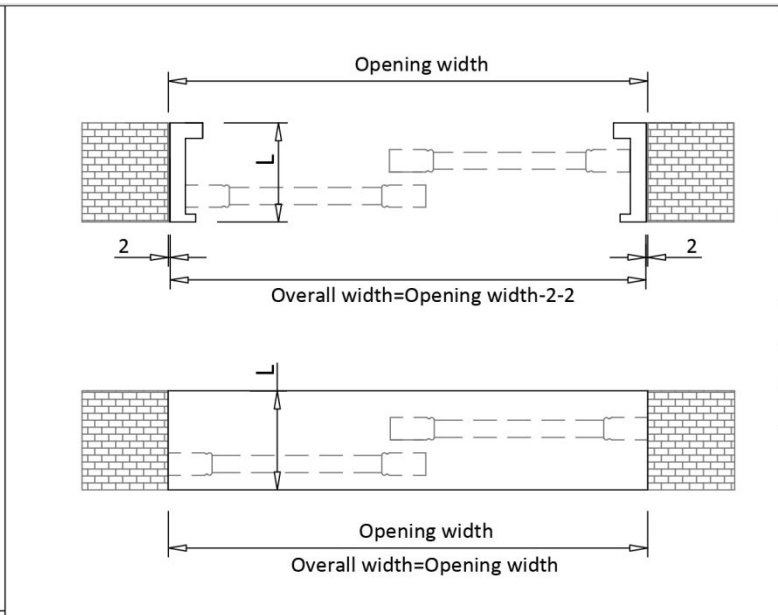
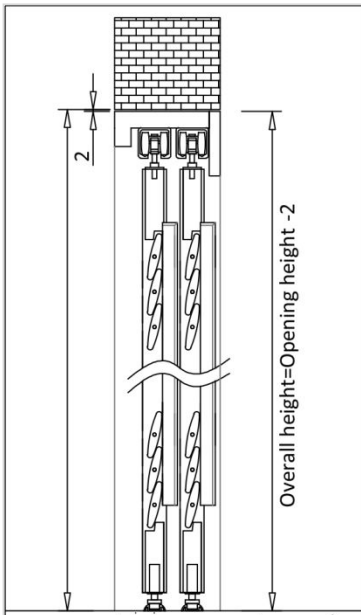

Mount in
side frames: Yes

L=the standard depth of frame

Louver size	depth
63.5mm	120mm
88.9mm	120mm

Mount in
side frames: no

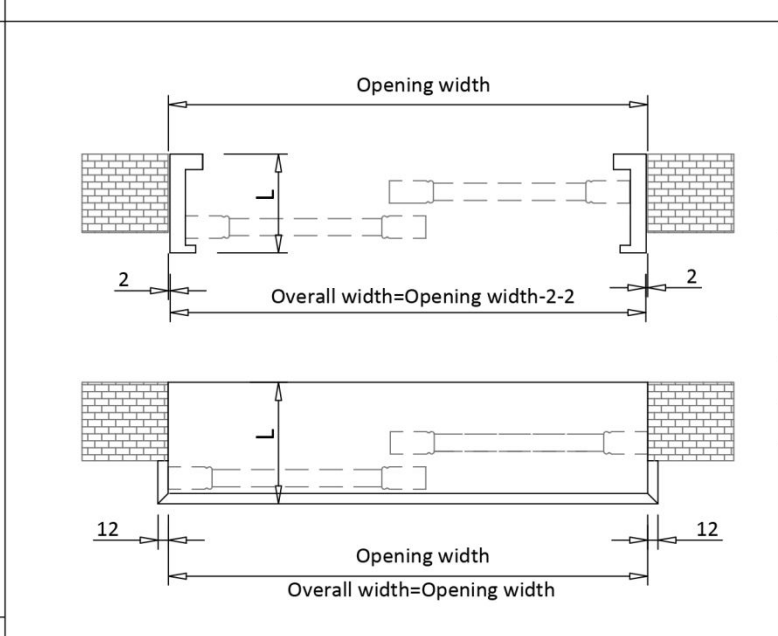
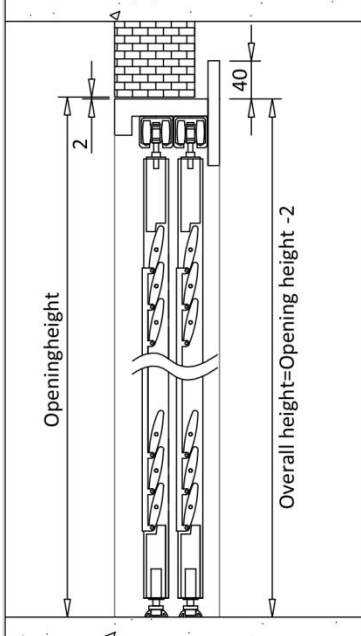

Semi-mount in
side frames: Yes

L=the standard depth of frame

Louver size	depth
63.5mm	120mm
88.9mm	120mm

Semi-mount in
side frames: no

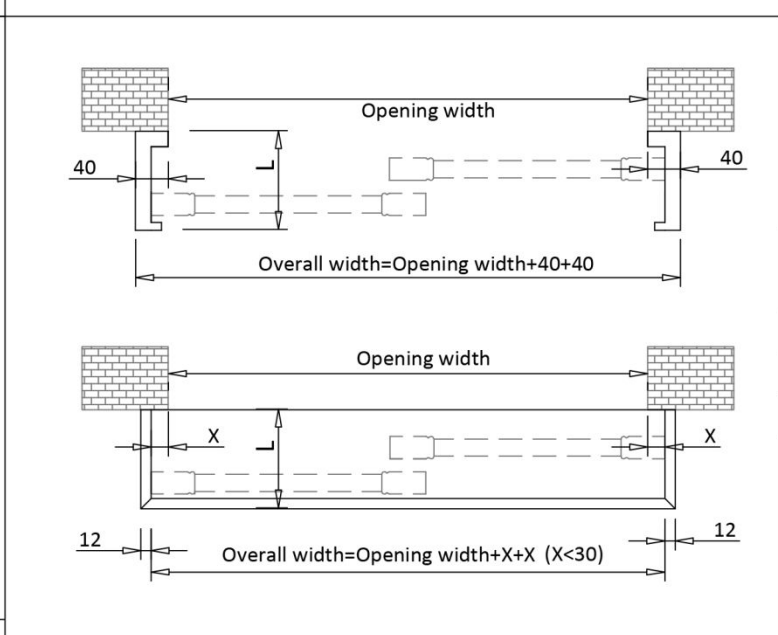
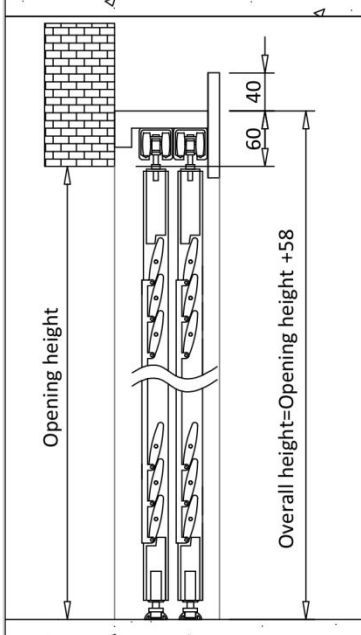

Mount out
side frames: Yes

L=the standard depth of frame

Louver size	depth
63.5mm	120mm
88.9mm	120mm

Mount out
side frames: no

Overall Size

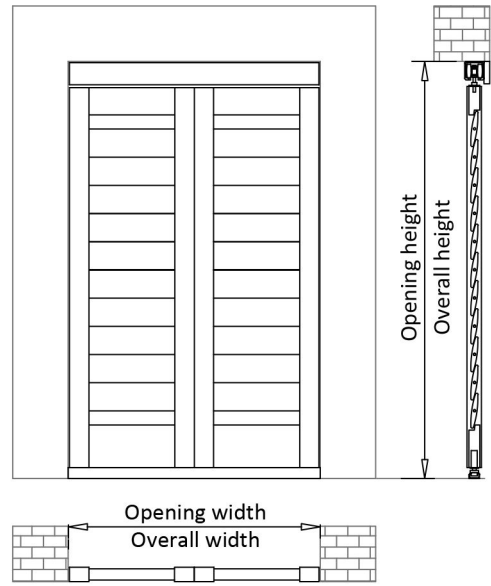
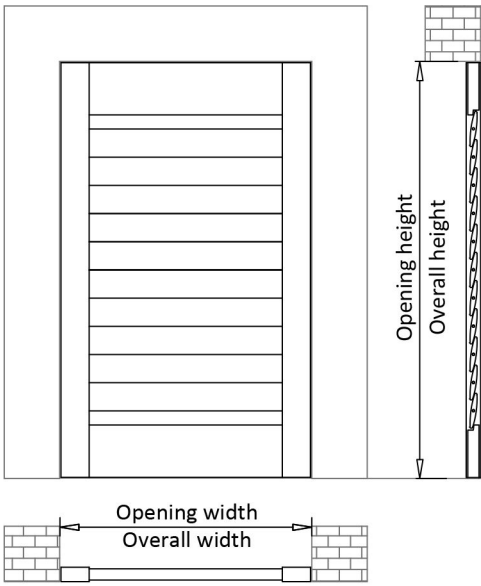

Frame type:	No frame	Frame sides:	None
Hardware:	None	Installation:	Mount in
Overall height:	= Opening height		
Overall width:	= Opening width		

Frame type:	None	Frame sides:	None
Hardware:	Track system	Installation:	Mount in
Overall height:	= Opening height		
Overall width:	= Opening width		

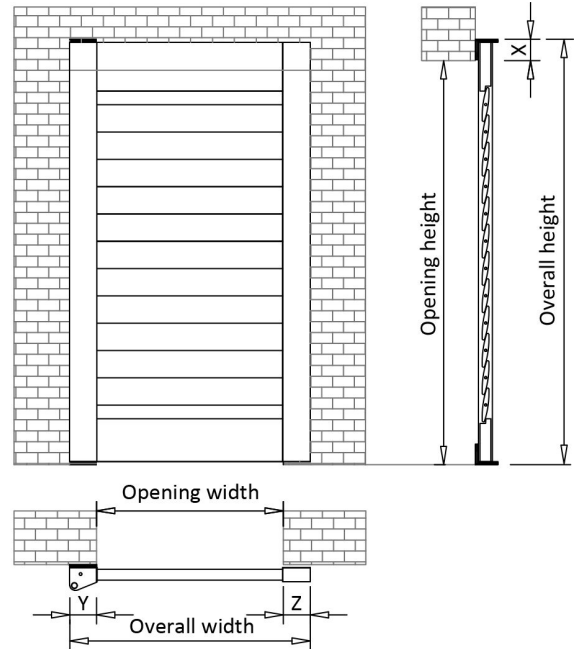
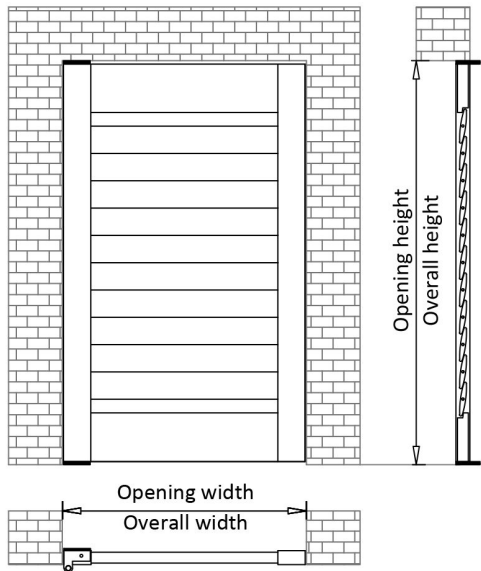

Frame type:	None	Frame sides:	None
Hardware:	Inside mounted pivot	Installation:	Mount in
Overall height:	= Opening height		
Overall width:	= Opening width		

Frame type:	None	Frame sides:	None
Hardware:	outside mounted pivot	Installation:	Mount out
Overall height:	= Opening height+X		
Overall width:	= Opening width +Y+Z		

Overall Size

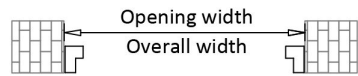
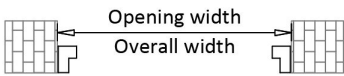
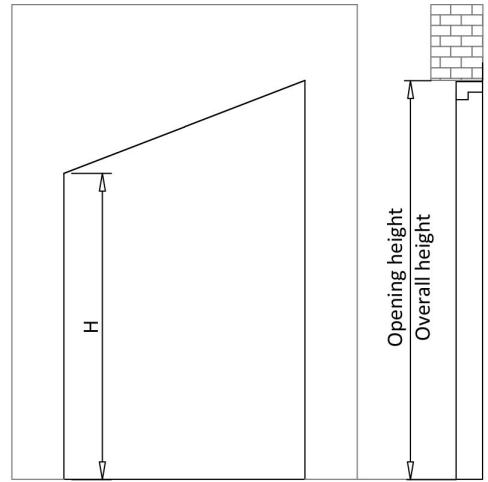
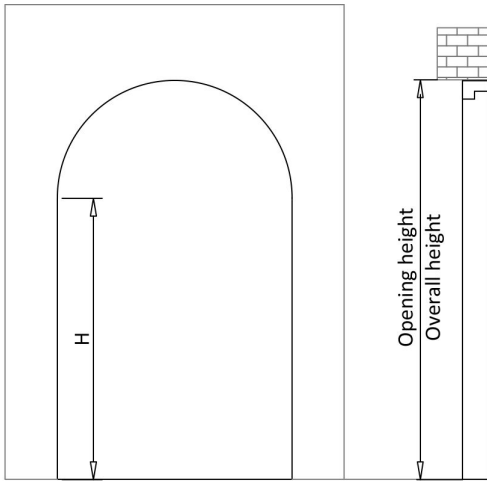

Frame type:	L shaped frame	Frame sides:	/
Hardware:	/	Installation:	Mount in
Overall height:	= Opening height		
Overall width:	= Opening width		

Frame type:	L shaped frame	Frame sides:	/
Hardware:	/	Installation:	Mount in
Overall height:	= Opening height		
Overall width:	= Opening width		

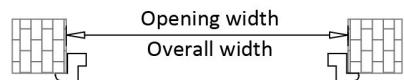
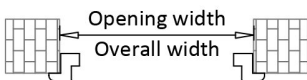
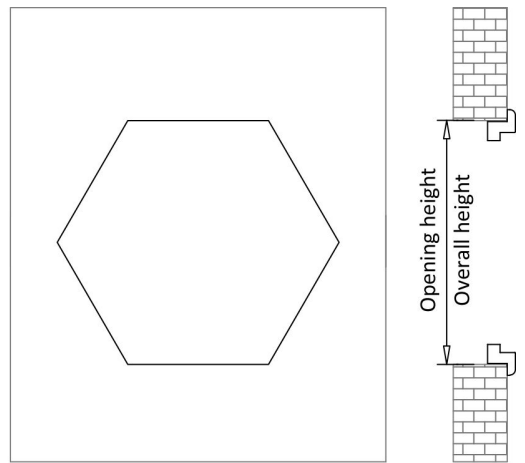
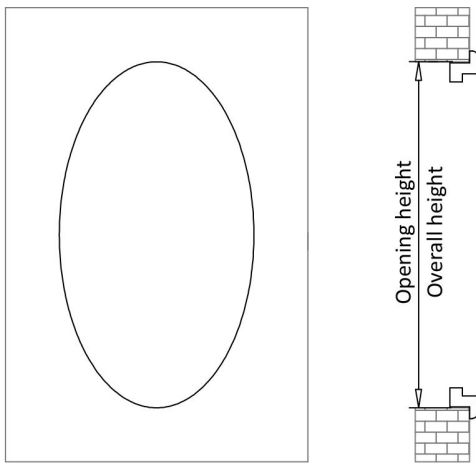

Frame type:	Z shaped frame	Frame sides:	4LRTB
Hardware:	/	Installation:	Mount in
Overall height:	= Opening height		
Overall width:	= Opening width		

Frame type:	Z shaped frame	Frame sides:	4LRTB
Hardware:	/	Installation:	Mount in
Overall height:	= Opening height		
Overall width:	= Opening width		

The frames used for track system only available for 63.5mm and 88.9mm louver sizes. We will match the corresponding frame depth shown in the table according to the louver size you choose. If you prefer a different frame depth please write down the required depth on the order form. Please note the frame depths shown in the table are the minimum depths that ensure the panels open or slide freely on the tracks, which are regarded as the standard frame depths.

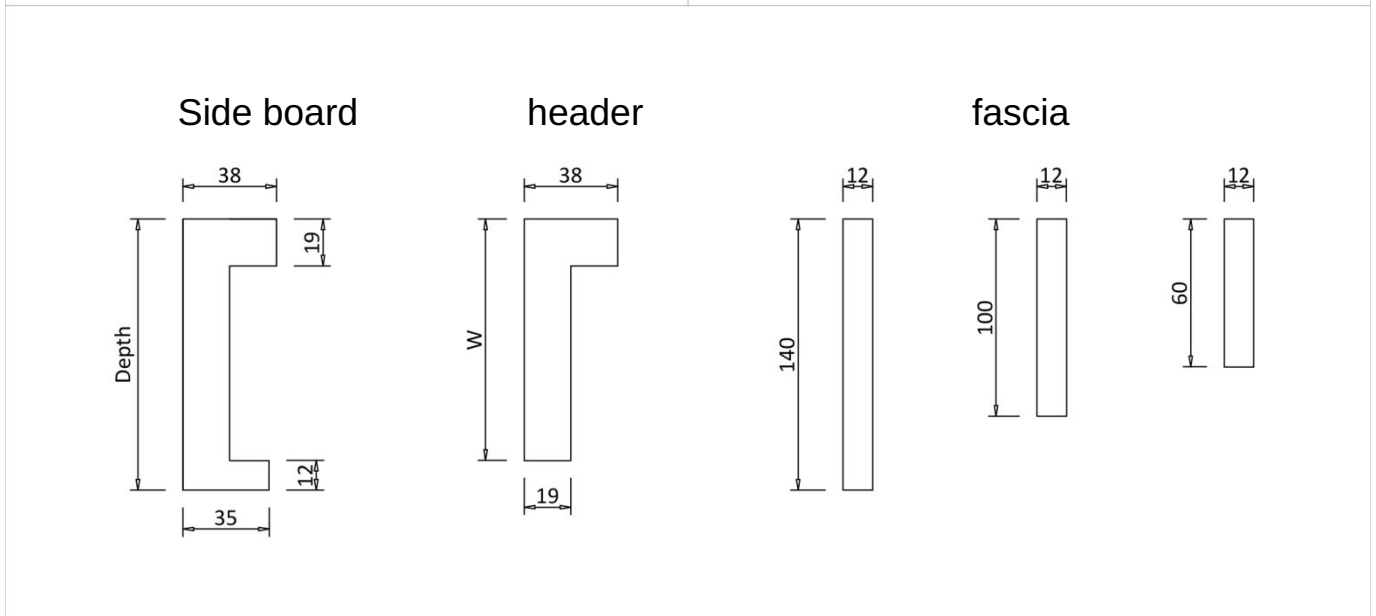
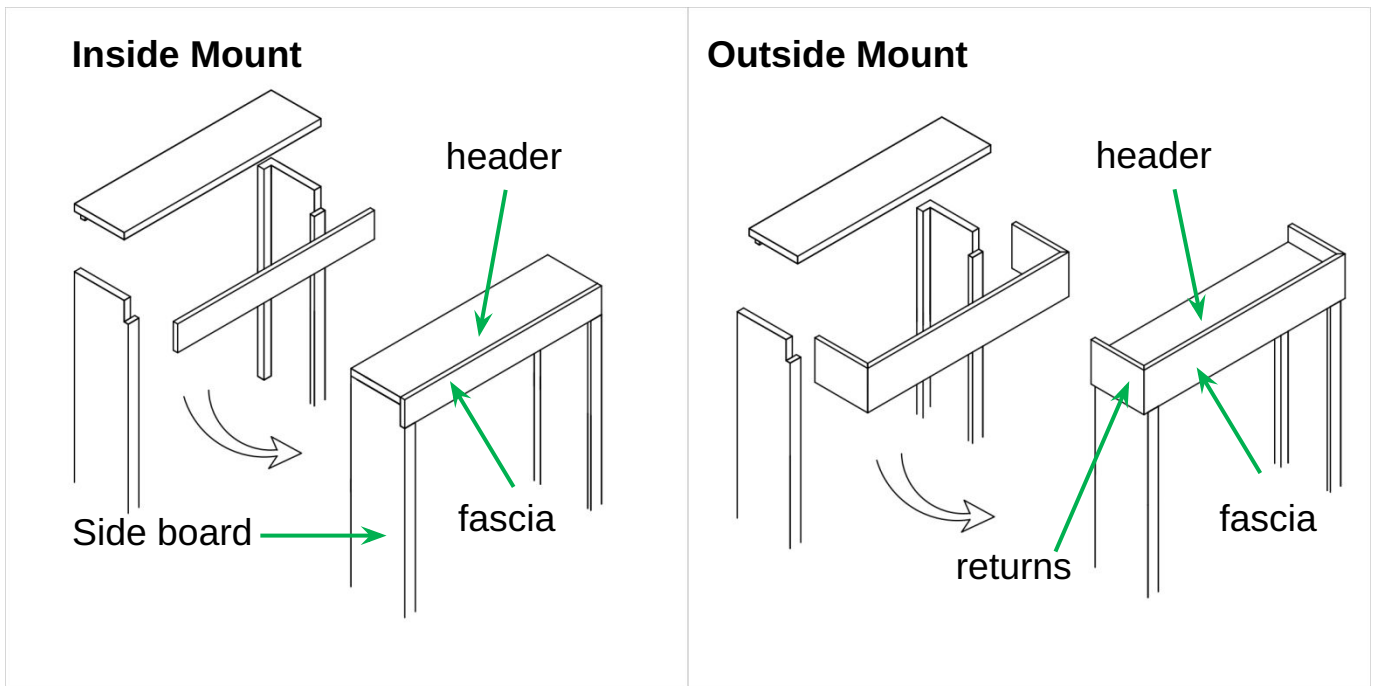

Inside Mount

<p>Side view</p>			the standard depth of frame		
	<p>Frame side: <u>3LRT</u></p> <p>Top frame: <u>Yes</u></p> <p>Left and right frame: <u>Yes</u></p> <p>Bottom board: <u>N/A</u></p> <p>Bottom track: <u>N/A</u></p>	<p>Frame side: <u>3LRT</u></p> <p>Top frame: <u>Yes</u></p> <p>Left and right frame: <u>Yes</u></p> <p>Bottom board: <u>N/A</u></p> <p>Bottom track: <u>Yes</u></p>	<p>Frame side: <u>4LRTB</u></p> <p>Top frame: <u>Yes</u></p> <p>Left and right frame: <u>Yes</u></p> <p>Bottom board: <u>Yes</u></p> <p>Bottom track: <u>Yes</u></p>	Louver size 63.5mm 88.9mm	Middle rod 85mm 100mm
<p>Option A</p>	<p>Option B</p>	<p>Option C</p>			

Outside Mount

<p>Side view</p>			the standard depth of frame		
	<p>Frame side: <u>3LRT</u></p> <p>Top frame: <u>Yes</u></p> <p>Left and right frame: <u>Yes</u></p> <p>Bottom board: <u>N/A</u></p> <p>Bottom track: <u>N/A</u></p>	<p>Frame side: <u>3LRT</u></p> <p>Top frame: <u>Yes</u></p> <p>Left and right frame: <u>Yes</u></p> <p>Bottom board: <u>N/A</u></p> <p>Bottom track: <u>Yes</u></p>	<p>Frame side: <u>4LRTB</u></p> <p>Top frame: <u>Yes</u></p> <p>Left and right frame: <u>Yes</u></p> <p>Bottom board: <u>Yes</u></p> <p>Bottom track: <u>Yes</u></p>	Louver size 63.5mm 88.9mm	Middle rod 85mm 100mm
<p>Option A</p>	<p>Option B</p>	<p>Option C</p>			

Inside Mount

Side view

Option A Option B Option C

the standard depth of frame		
Louver size	Middle rod	Hidden rod
63.5mm	175mm	
88.9mm	210mm	

	Option A	Option B	Option C
<u>Frame side:3LRT</u>	<u>Frame side:3LRT</u>	<u>Frame side:3LRT</u>	<u>Frame side:4LRTB</u>
<u>Top frame: Yes</u>	<u>Top frame: Yes</u>	<u>Top frame: Yes</u>	<u>Top frame: Yes</u>
<u>Left and right frame: Yes</u>	<u>Left and right frame: Yes</u>	<u>Left and right frame: Yes</u>	<u>Left and right frame: Yes</u>
<u>Bottom board:N/A</u>	<u>Bottom board:N/A</u>	<u>Bottom board:N/A</u>	<u>Bottom board:Yes</u>
<u>Bottom T guide:Yes</u>	<u>Bottom track:Yes</u>	<u>Bottom track:Yes</u>	<u>Bottom track:Yes</u>

Outside

Side view

Option A Option B Option C

the standard depth of frame		
Louver size	Middle rod	Hidden rod
63.5mm	175mm	
88.9mm	210mm	

	Option A	Option B	Option C
<u>Frame side:3LRT</u>	<u>Frame side:3LRT</u>	<u>Frame side:3LRT</u>	<u>Frame side:4LRTB</u>
<u>Top frame: Yes</u>	<u>Top frame: Yes</u>	<u>Top frame: Yes</u>	<u>Top frame: Yes</u>
<u>Left and right frame: Yes</u>	<u>Left and right frame: Yes</u>	<u>Left and right frame: Yes</u>	<u>Left and right frame: Yes</u>
<u>Bottom board:N/A</u>	<u>Bottom board:N/A</u>	<u>Bottom board:N/A</u>	<u>Bottom board:Yes</u>
<u>Bottom T guide:Yes</u>	<u>Bottom track:Yes</u>	<u>Bottom track:Yes</u>	<u>Bottom track:Yes</u>

Sliding Track System (light block)

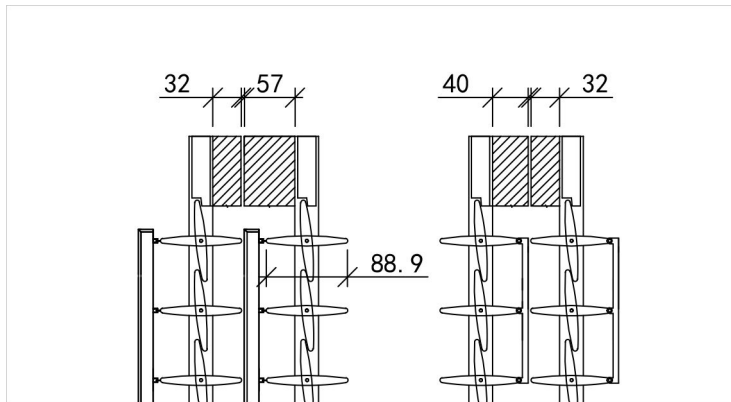
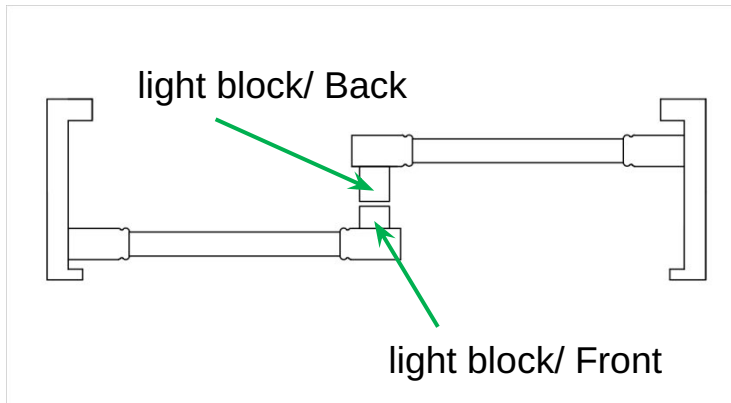

Louver type:	Rod type	Rod type
88.9mm	Middle Rod	Hidden Rod
Light Block's width(F) :	32mm	40mm
Light Block's width(B) :	57mm	32mm

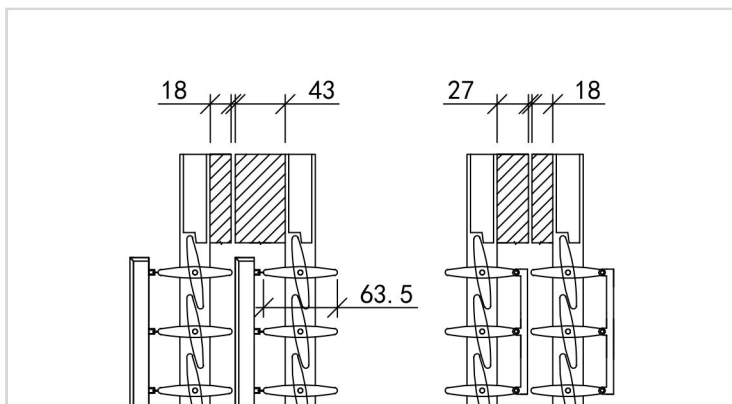

Louver type:	Rod type	Rod type
63.5mm	Middle Rod	Hidden Rod
Light Block's width(F) :	18mm	27mm
Light Block's width(B) :	43mm	18mm

Inside Mount

Side view

Overall width=Opening width-2-2
Opening width

the standard depth of frame		
Louver size	Middle rod	Hidden rod
63.5mm	120mm	
88.9mm	120mm	

	Option A	Option B	Option C
<p><u>Frame side:3LRT</u></p> <p><u>Top frame: Yes</u></p> <p><u>Left and right frame: Yes</u></p> <p><u>Bottom board:N/A</u></p> <p><u>Bottom T guide:Yes</u></p>	<p><u>Frame side:3LRT</u></p> <p><u>Top frame: Yes</u></p> <p><u>Left and right frame: Yes</u></p> <p><u>Bottom board:N/A</u></p> <p><u>Bottom track:Yes</u></p>	<p><u>Frame side:4LRTB</u></p> <p><u>Top frame: Yes</u></p> <p><u>Left and right frame: Yes</u></p> <p><u>Bottom board:Yes</u></p> <p><u>Bottom track:Yes</u></p>	

Outside Mount

Side view

Opening width

Overall width=Opening width+40+40

the standard depth of frame		
Louver size	Middle rod	Hidden rod
63.5mm	120mm	
88.9mm	120mm	

	Option A	Option B	Option C
<p><u>Frame side:3LRT</u></p> <p><u>Top frame: Yes</u></p> <p><u>Left and right frame: Yes</u></p> <p><u>Bottom board:N/A</u></p> <p><u>Bottom T guide:Yes</u></p>	<p><u>Frame side:3LRT</u></p> <p><u>Top frame: Yes</u></p> <p><u>Left and right frame: Yes</u></p> <p><u>Bottom board:N/A</u></p> <p><u>Bottom track:Yes</u></p>	<p><u>Frame side:4LRTB</u></p> <p><u>Top frame: Yes</u></p> <p><u>Left and right frame: Yes</u></p> <p><u>Bottom board:Yes</u></p> <p><u>Bottom track:Yes</u></p>	

Staggered Centre Tilt Rod

When more than three panels are folded at one side, the centre tilt rod will be staggered to avoid damage.

The middle rods of all the panels will be automatically staggered by 7mm to the same direction to avoid any collision.

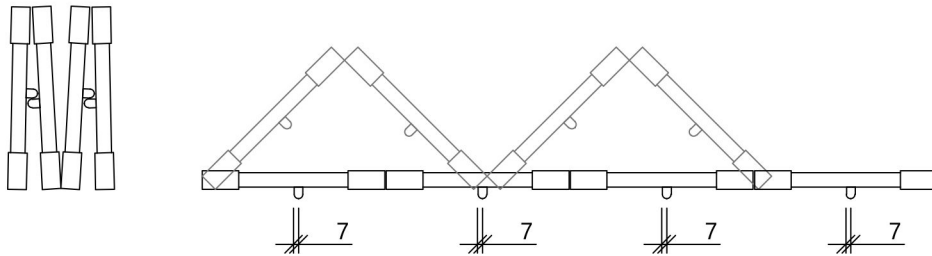
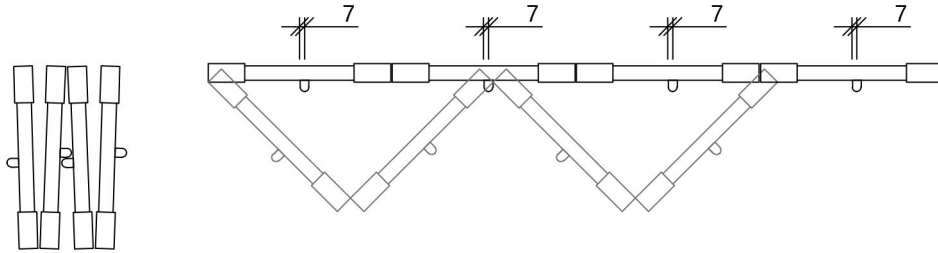

Height of Divider Rail

For Full Height Shutters

When the mount type is "Inside", measurement starts from bottom of the opening to the center point of each divider.(same for all inside mount frames, such as L frames, Z frames. If only 1 divider is required, see H1 on drawing 1 and drawing 2.If two dividers are required, see H1,H2 on drawing 4 and drawing 5.)

When the mount type is "Outside", Measurement starts from bottom of the frame to the center point of each divider. (same for all outside mount frames, such as L frames. If only 1 divider is available, see H1 on drawing 3.If two dividers are required, see H1,H2 on drawing6.)

1 divider(1-3)

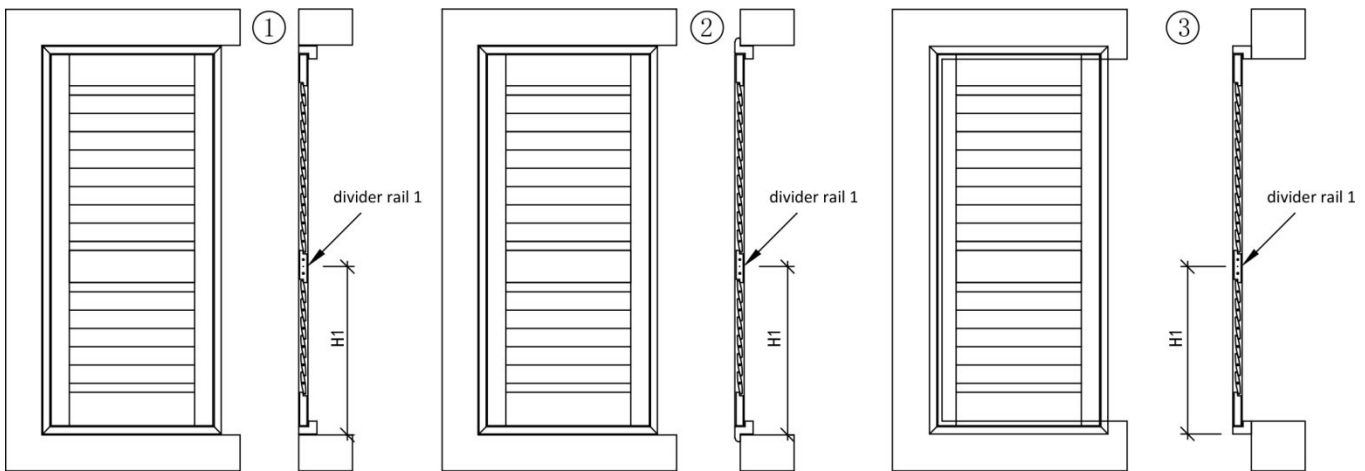

2 dividers(4-6)

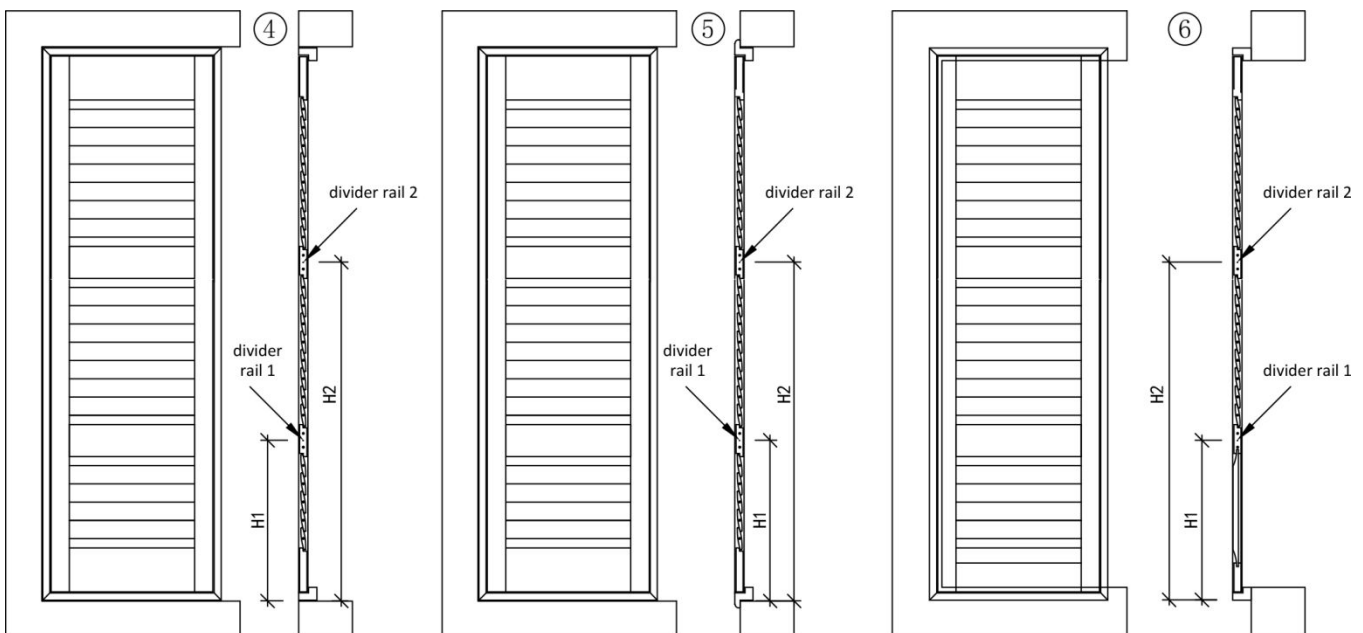

Tier on Tier Shutters

Please note if no horizontal T post, the break between top and bottom panels should always be filled in the column of “Divider-1” on the order form. If the mount type is inside, the break should be measured from the top of the bottom panels till the bottom of the opening. If the mount type is outside, the break should be measured from the top of the bottom panels to the bottom of the frame.

When using a horizontal T post. The divider is measured from the bottom of the opening or frame to the center point of the T post.

No horizontal T post (1-3)

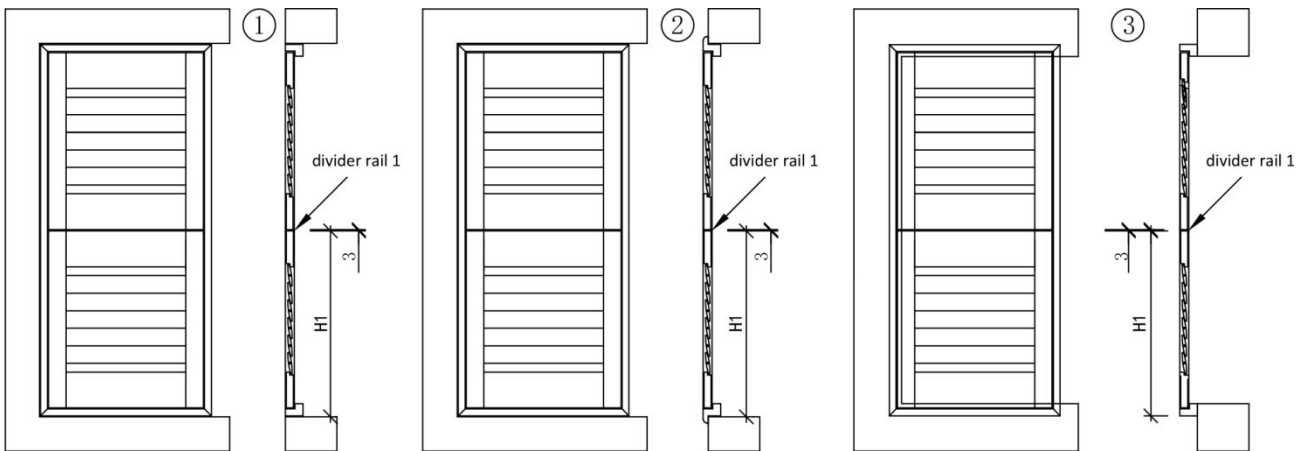

With horizontal T post(4-6)

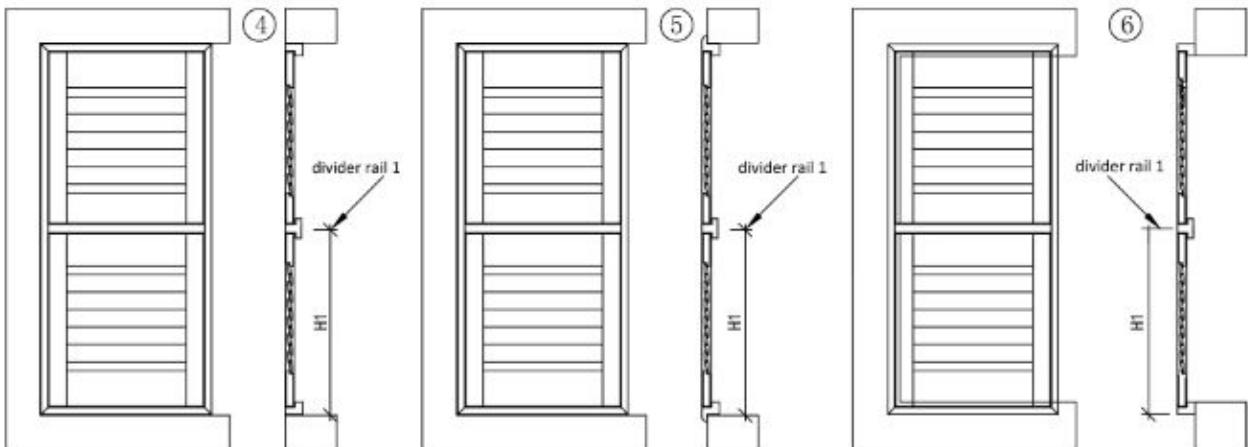

Rod Split

Split tilt rod measurement: From the bottom point of the overall height (the bottom of the frame or floor) to the desired split height H1. Split tilt tolerance $\pm \frac{1}{2}$ Louvre

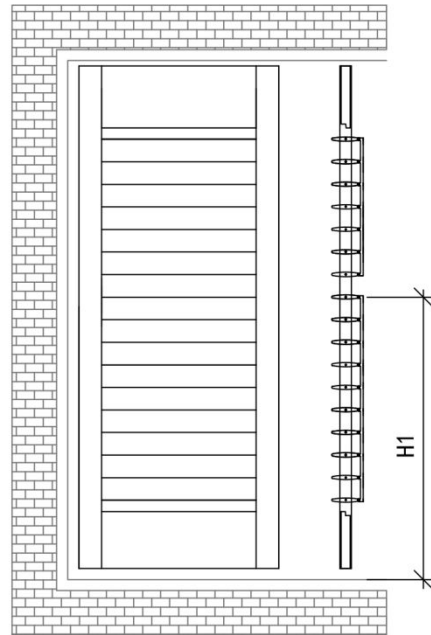
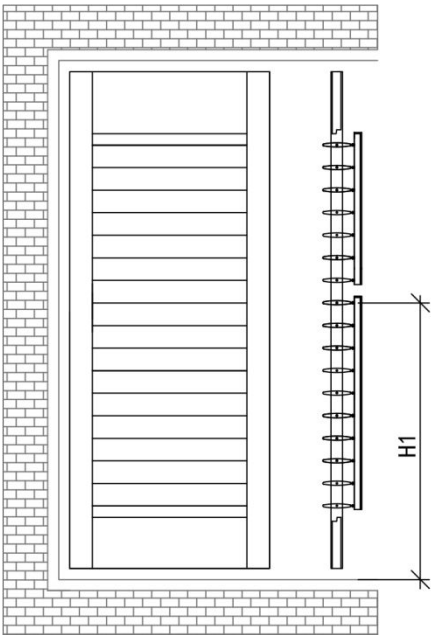

Hidden rods are split automatically when the number of louvers connected to the rod exceeds the following limits:

Louver size	Louver Quantity
63.5	≥ 20
88.9	≥ 13
114.3	≥ 10

If the louver quantity is odd, the bottom rod will be longer than the top.
if the louver quantity is even, the rod will be split in half.

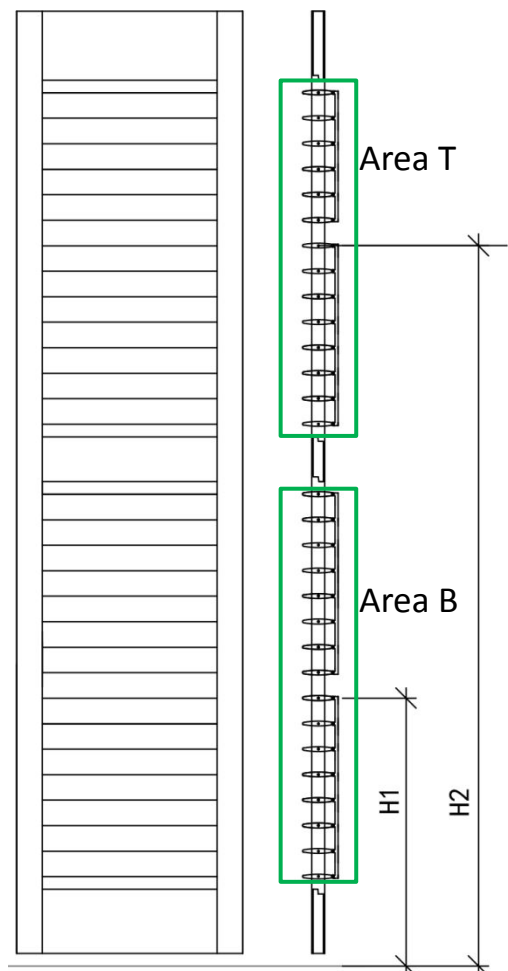

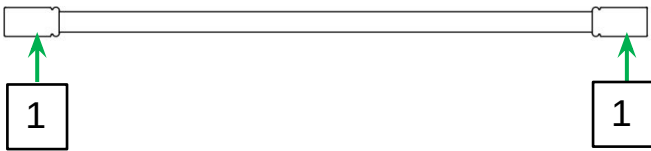

Config: L / R
Butt stile

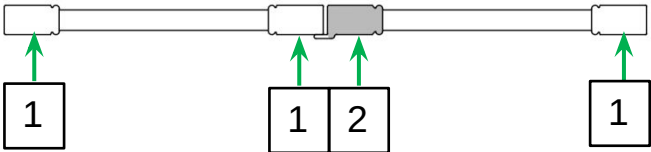

Config: L - DR
D-mould stile

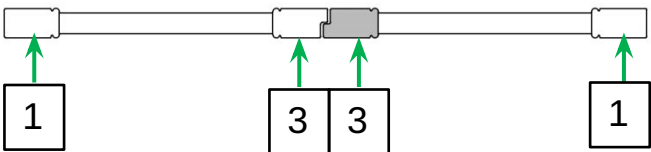

Config: LL / RR
Rebate stile

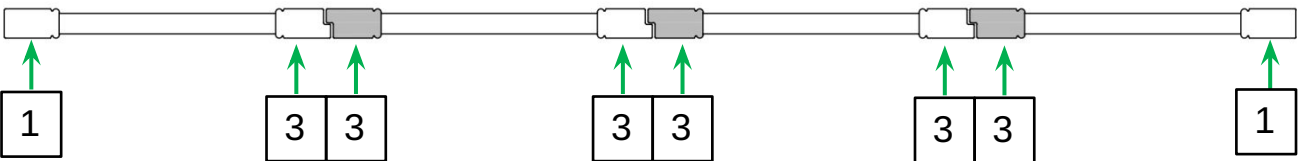

Config: LLRR / LLLL / RRRR
Rebate stile

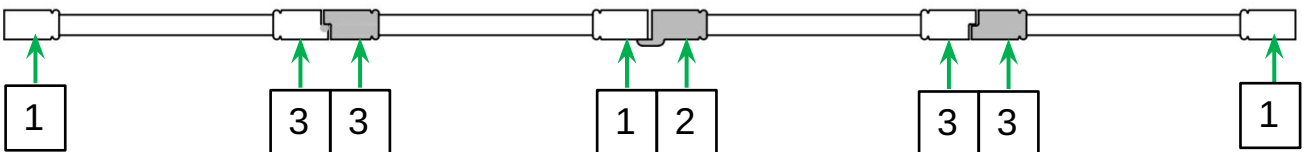

Config: LL - DRR
Rebate stile

Stile type	Level
Butt stile	1
D-mould stile	2
Rebate stile	3

Fixed louvers mean the louvers cannot move and no rod exists. The fixed louvers could be opened to a certain degree, but normally not exceeds the stile.

Drawing B is the standard (louvres closed).

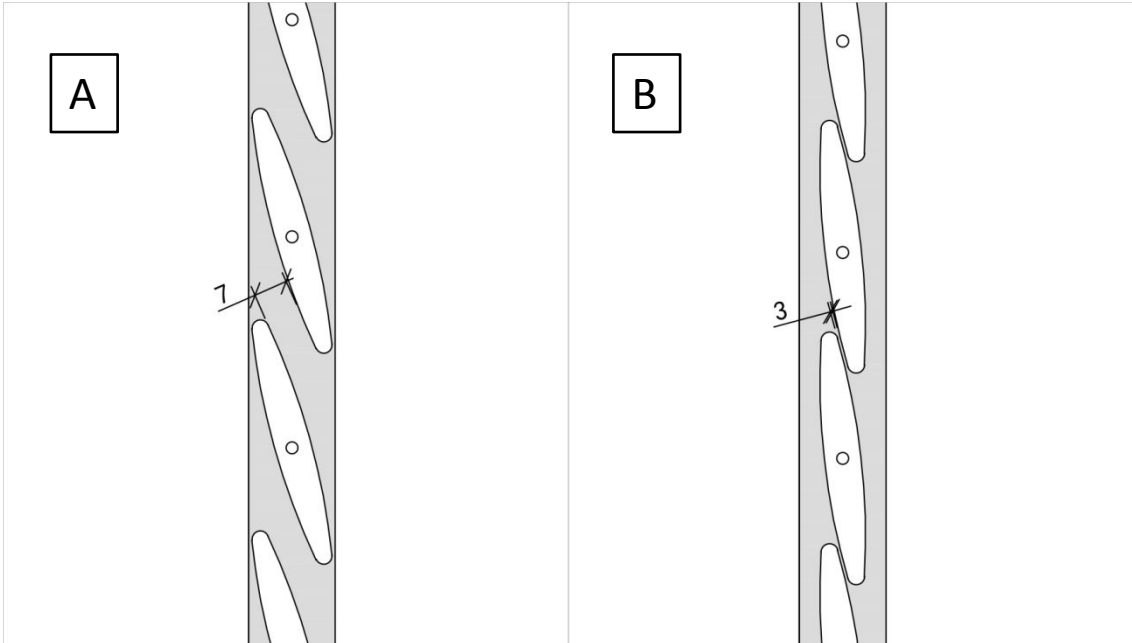

Drawing A: The fixed louvers are opened with certain degree

Drawing B: The fixed louvers are fully closed without any degree



Hardware

Hinges

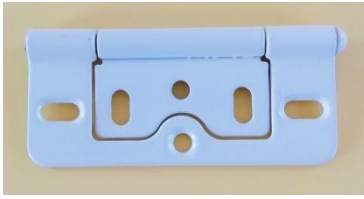

Non-mortise hinge 75mm



Rebate hinge 75mm

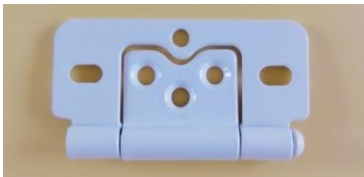

Non-mortise hinge 62mm

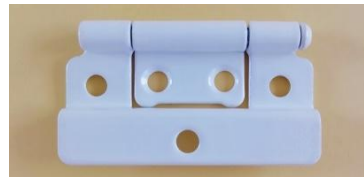

Rebate hinge 62mm



Inside pivot 3mm rebate



Outside pivot 6mm rebate



L shaped hinge 75mm



L- shaped Clearview

We've aimed to include the necessary technical information in this manual.

How to measure, how to correctly select the options from the drop-down box on the order form and how to avoid order mistakes.

The purpose of this manual is to help distributors easily understand our specifications and ordering system.

If you need any help please make contact with one of our support team.

We are constantly updating and improving so we appreciate any further suggestions from you.

<https://www.betta-blinds.com.au>